

Rotary Unit Operation Manual

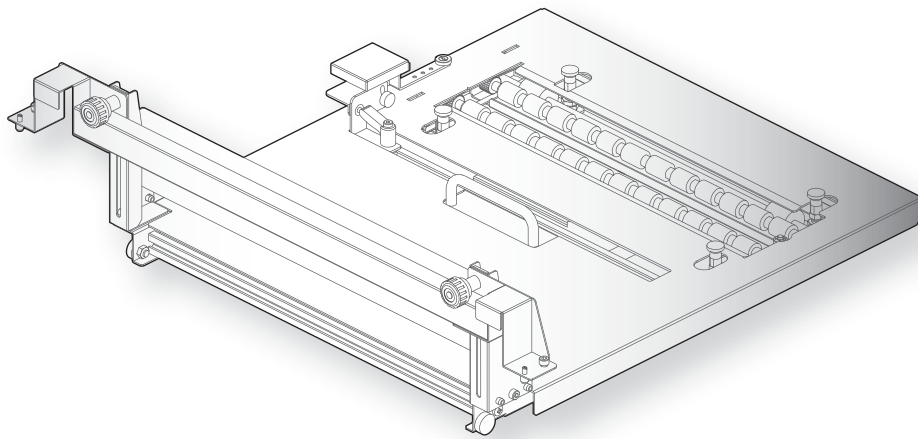

Unpacking	2
Attaching the Rotary Unit	7
Nozzle check and cleaning	14
Loading the media	24
Basic printing instructions	32
Detaching the Rotary Unit	36
Maintenance	41
Messages and Error Messages	45
Troubleshooting	47
Safety Instructions	52
Revision History	55

-
- Unauthorized copying or duplication of the whole or part of the contents of this Manual is prohibited.
 - Every care has been taken in writing the contents of this Manual, but please contact MUTOH or the dealer you purchased the product from if you find any unclear, erroneous or otherwise unsatisfactory content in the Manual.
 - Please be aware that MUTOH will not be liable in any way for failures or accidents that result from handling or operating the printer according to any procedures other than those set forth in this Manual.
 - Company names and product names that appear in this Manual are registered trademarks of the respective companies.
 - This operation manual is intended for users of VJ-626UF.
If you are using Rotary Unit on the printer other than VJ-626UF, download "Rotary Unit Operation Manual (Model: IJ-RTU-01)" from MUTOH Club (<https://club.mutoh.co.jp/mutoh/guser/>) or contact MUTOH or your local MUTOH dealer.

Unpacking

Unpacking the Unit

- [1] Open the packing box. Remove the packing materials, and take out accessory items and Rotary Unit.

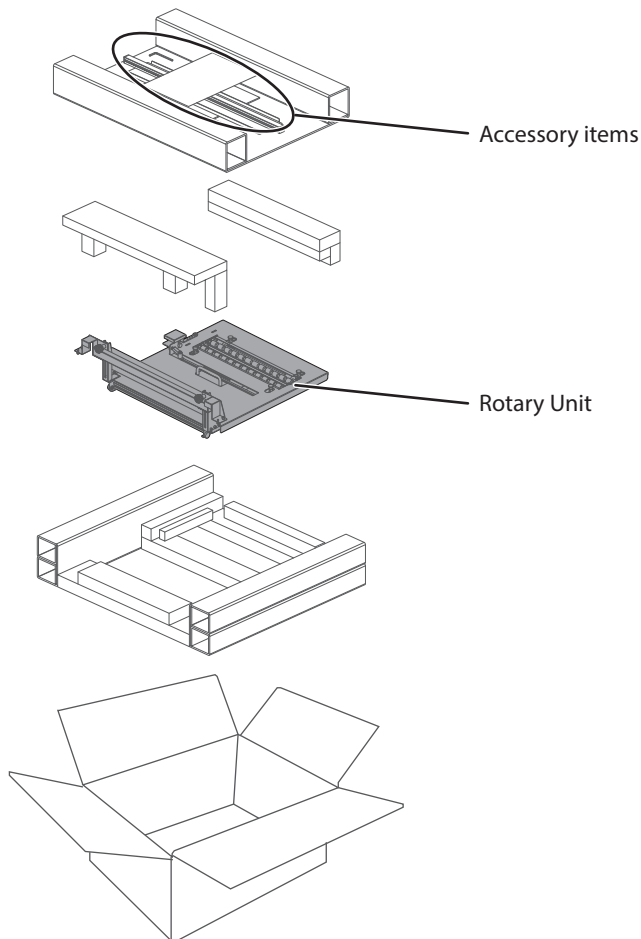

⚠ CAUTION

- When carrying this product, always hold the handle with one hand, and put the other hand lightly on the attachment or side of the product. Do NOT hold rollers or media retainer. It can cause damage to the Unit.
- When holding the side of the product, make sure to hold the black cover and silver frame on each side of the unit. If holding the black cover only, you may have a chance to drop the product or the cover can be deformed, leading to poor print quality.

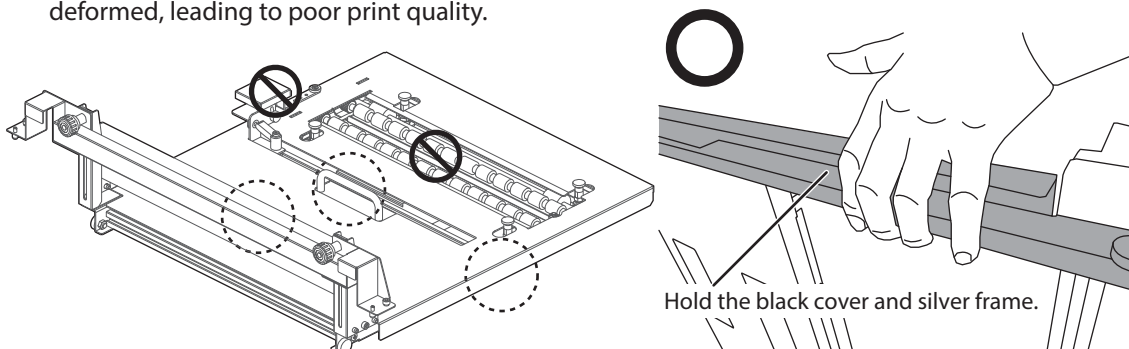

[2] Check that the following items are included.

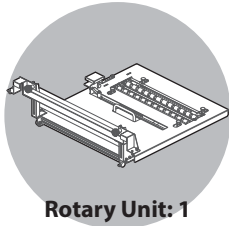

Rotary Unit: 1

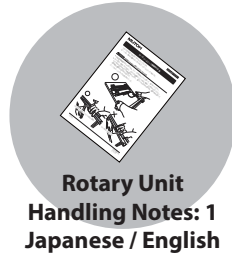

**Rotary Unit
Handling Notes: 1
Japanese / English**



**Operation Manual:
Japanese / English
(this document)**

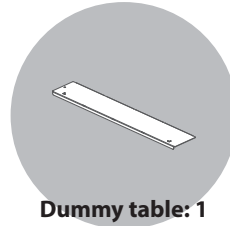

Dummy table: 1



Guide bar: 1



Hex wrench: 1



Note

Dummy table is used for a nozzle check while the Rotary Unit is installed in the printer.

Required items for installing the Unit

To install the Unit, you will need the following item in addition to the accessory items.



**Phillips-head
screwdriver: 1**



Note

- The firmware version 1.03 or later supports Rotary Unit. Before using Rotary Unit, check that the supported firmware is installed on the printer.
If old version is installed in your computer, download the latest version from MUTOH Club (user registration required).
MUTOH Club <https://club.mutoh.co.jp/mutoh/guser/>
- To perform a cylindrical printing on a cylindrical object, the supported application is also needed. The supported application is stored in the supplied CD-ROM Version 20 or later. If you have earlier version of CD-ROM, please download the application from the MUTOH Club server.
- If you are using Rotary Unit on the printer other than VJ-626UF, see the relevant operation manual for firmware and print application requirements.

 ["About the operation manual" P.3](#)

About the operation manual

This operation manual is intended for users of VJ-626UF.

If you are using Rotary Unit on the printer other than VJ-626UF, download "Rotary Unit Operation Manual (Model: IJ-RTU-01)" from MUTOH Club (<https://club.mutoh.co.jp/mutoh/guser/>) or contact MUTOH or your local MUTOH dealer.

Name of each part

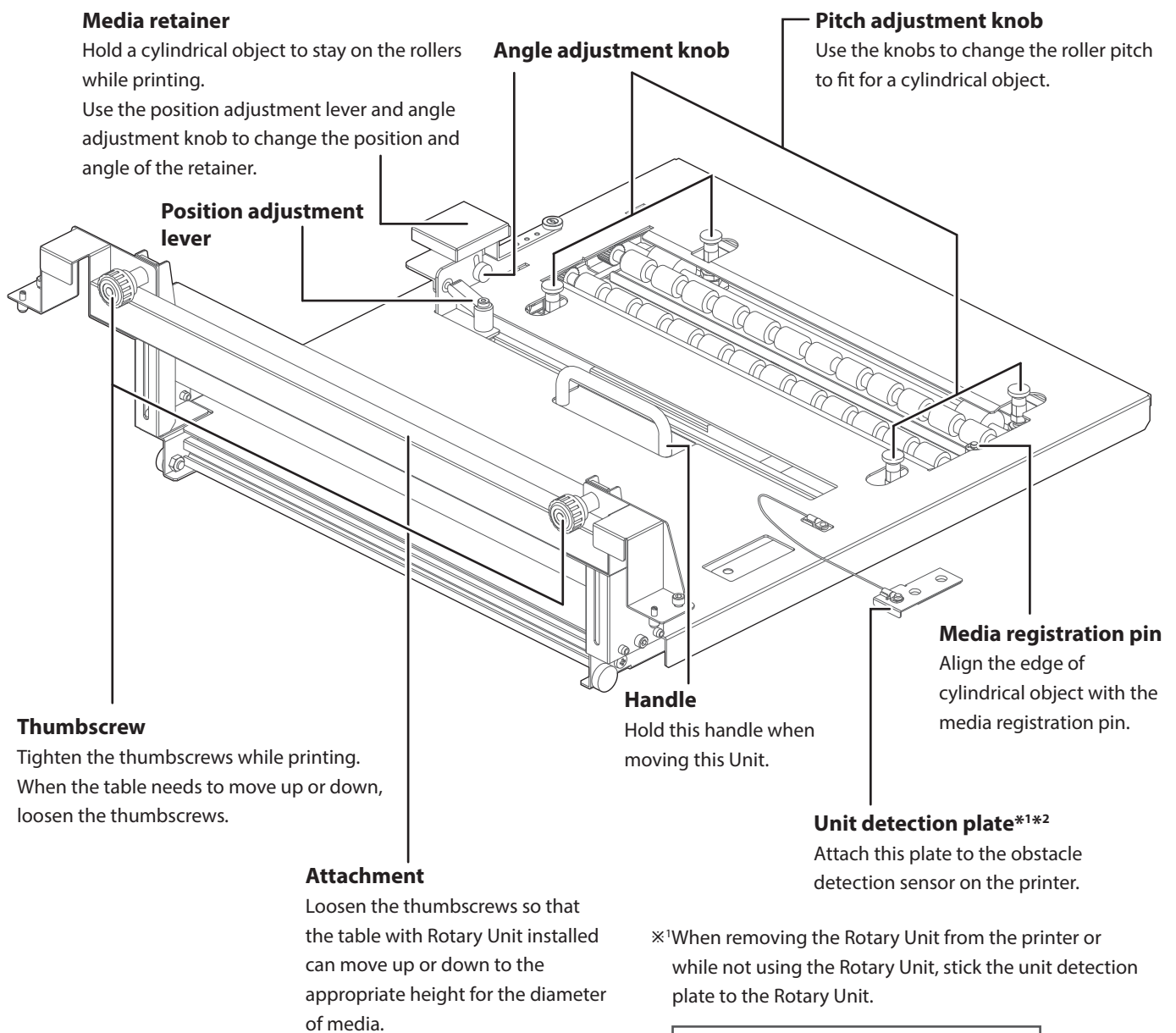

※¹When removing the Rotary Unit from the printer or while not using the Rotary Unit, stick the unit detection plate to the Rotary Unit.

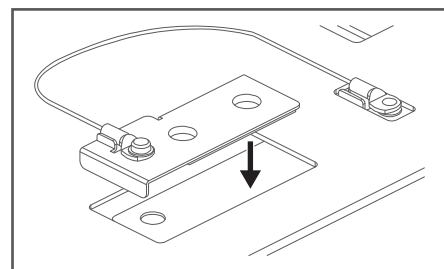

※² To use Rotary Unit on a printer model other than VJ-626UF, you must replace the unit detection plate with the designated part. For more details, please contact MUTOH or your local MUTOH dealer.

Environmental Condition

Use this Unit under the following printer environmental condition:

 VJ-626UF Startup Guide

Environmental conditions (complies with the printer operating condition)	Operating environment	Temperature 20 to 32 °C, Humidity 40 to 60% No condensation
	Recommended Printing Environment	Temperature 22 to 30 °C, Humidity 40 to 60% No condensation
	Environment for storage	Temperature -20 to +60 °C, Humidity 20 to 80%

Requirements for usable media

Usable media

Printable objects	Cylindrical rigid object *Cylindricity: Up to 0.5 (print quality is not guaranteed)
Diameter	Φ 30 mm to Φ 120 mm
Maximum width	360 mm
Maximum Weight	1.0 kg

WARNING

**Do NOT print on containers, bottles or packaging used for food or drink application.
Do NOT print on areas where can directly or potentially contact with mouth.**

Important!

**The minimum media width and length that are settable in the User Type for the printer are 30 mm x 20 mm.
When printing on an object smaller than this, take extra care not to print on the Rotary Unit.
Once UV ink cures on the Unit, you can hardly remove it.**

Note

Contact your local MUTOH dealer about roll media recommended for your printer.

Cautions for handling media

To achieve expected print quality, follow the instructions below.
Failure to follow these instructions could result in damage to the printer.

- Do NOT use heat-sensitive media.
It can be deformed by prolonged irradiation from the UV-LED lamp, or affect its image quality, or cause it to contact with the head.
- Do NOT use light reflective object like a mirror or light transparent object that can cause irregular reflection of UV light.
This will cure the ink on the print head.
- Using ethanol or isopropyl alcohol used for disinfectant, clean the surface of object before printing.
It helps to remove dirt and oil from the print area, and avoid static electricity as well.

Correctly load and set up media

When loading a new media, make sure to place it on an appropriate position and input correct media information.
If wrong media size is entered, the printer will print on unintended area on the Rotary Unit. It can also cause poor print quality, ink mist or head strike.

Enter the correct diameter of object as much as possible.
Before loading a cylindrical object, measure the actual diameter, then place it on the Rotary Unit.

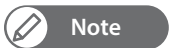

Note

Please also read "Precautions when using this printer" in the VJ-626UF Operation Manual.

Attaching the Rotary Unit

Note

If you are using Rotary Unit on the printer other than VJ-626UF, see the relevant operation manual for panel operation.

 ["About the operation manual" P.3](#)

Put Printer into Rotary Mode

You will need a Phillips-head screwdriver (commercially available) for this procedure.

[1]

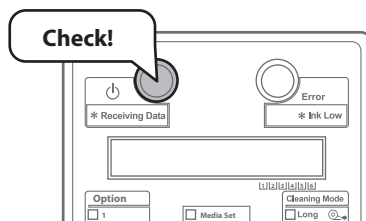

Make sure that the power button is turned on.

[2]

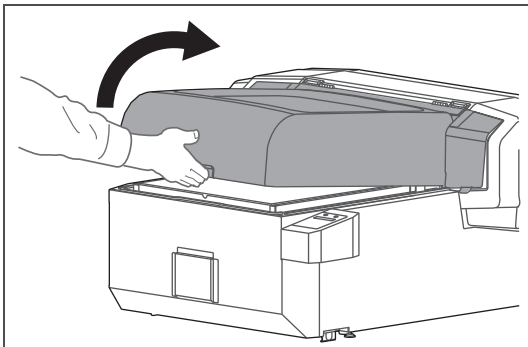

Open the front cover.

Note

Hold the handle on the front cover to gently open it.
Fully open the front cover.

[3]

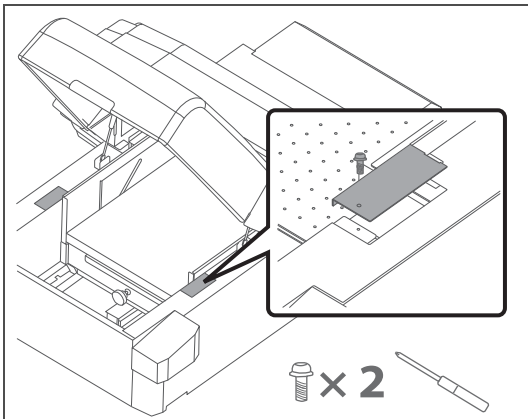

Use the Phillips-head screwdriver to remove the screws, and then remove the attachment covers (x2) from the printer.

Note

- If it is difficult to remove the covers, put the printer into Rotary Mode, then remove them from the printer.
- Make sure to keep the screws and attachment covers removed from the printer.

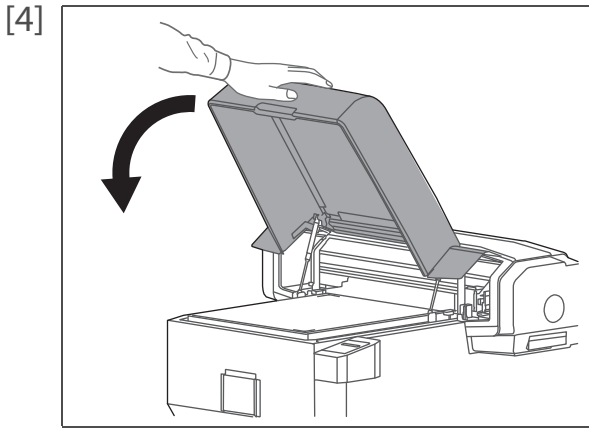

Close the cover.



Note

Hold the position shown on the left and gently close the cover.

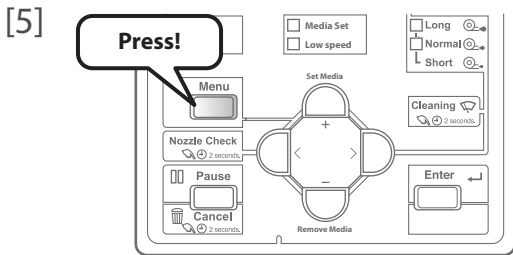

Press the [Menu] key.

Menu1:	Setup >
---------------	-------------------

- The message on the left will appear.

[6]

Menu5:	Option >
---------------	--------------------

Press the [-] key several times, to bring up the display on the left.

- Press the [>] key.

[7]

Option 1:	Rotary Unit
------------------	--------------------

Press the [Enter] key.

[8]

Rotary 1:	InstallUnit
------------------	--------------------

Press the [Enter] key.

[9]

Execute Menu?	No
----------------------	-----------

Press the [-] key.

[10]

Execute Menu?	Yes
----------------------	------------

Press the [Enter] key.

Wait for a while

The message on the left will appear.

[11]

Remove Media	-> Enter
---------------------	--------------------

Remove the media on the table, and then press the [Enter] key.

InstallRotaryUnit	-> E
--------------------------	----------------

- Next, you will install the Rotary Unit in the printer.

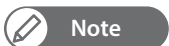

Note

You can cancel switching to Rotary Mode by pressing the [Cancel] key while the following message is displayed on the operation panel.

- "Remove Media ->Enter"
- "Install Rotary Unit -> E"

Install Rotary Unit

This procedure requires the hex wrench supplied with the printer.

CAUTION

- **When moving this Unit, always hold the handle and the area shown with dotted circles.**
Do NOT hold rollers or media retainer. It can cause damage to the Unit.
- **When holding the side of the product, make sure to hold the black cover and silver frame on each side of the unit.**
If holding the black cover only, you may have a chance to drop the product or the cover can be deformed, leading to poor print quality.

[1] Change the roller pitch to fit for a cylindrical object to be loaded.

- Narrow: $\Phi 30$ mm to $\Phi 80$ mm
- Wide: $\Phi 60$ mm to $\Phi 120$ mm

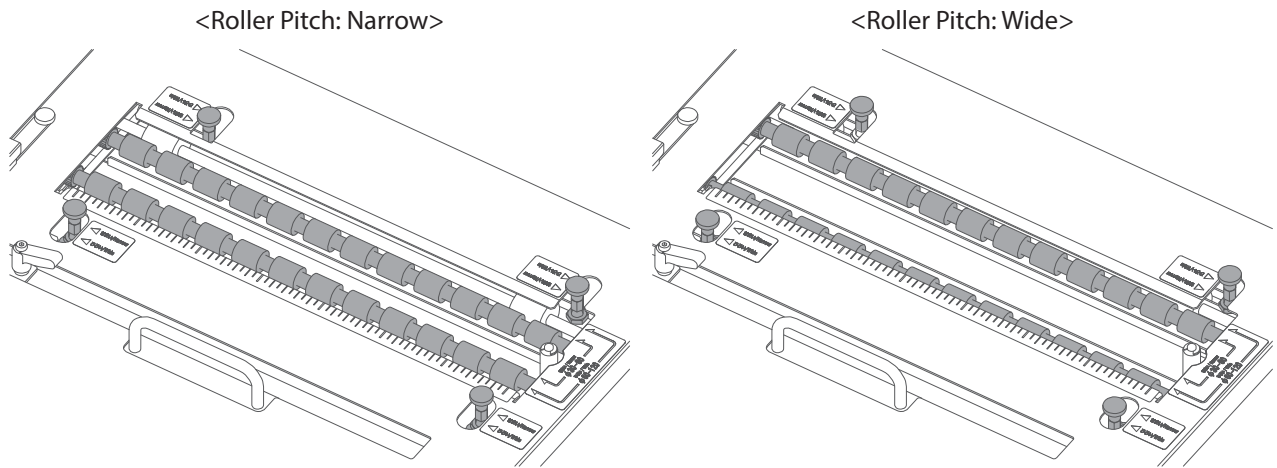

<How to change roller pitch>

- Pull up the knob and rotate it anticlockwise by 90 degrees to unlock it (x4).
- Then move the knobs to change the roller pitch.
- Once the pitch has been changed, rotate the knob clockwise by 90 degrees to lock it (x4).

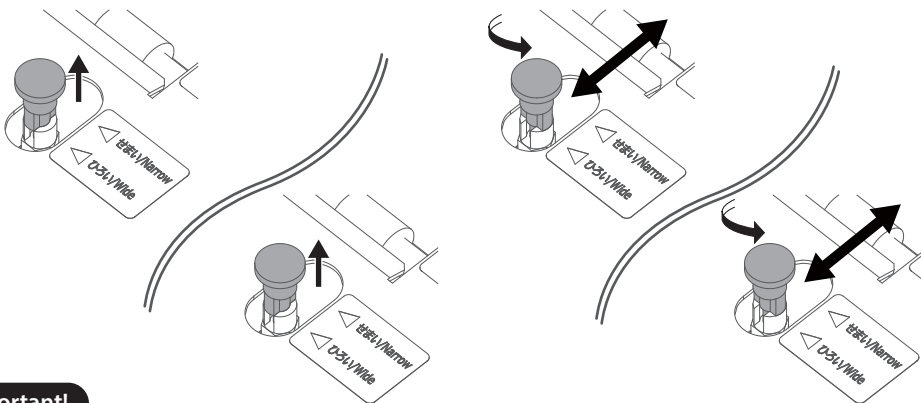

Important!

When changing the roller pitch, always slide the right and left knobs per roller at a time.
Do NOT slide one knob only or two knobs separately. The roller cannot move correctly.

Note

- All pitch adjustment knobs must be set to the same setting ("Narrow" or "Wide"). If not, the printer cannot print on an object correctly.
- If you are using $\Phi 60$ to $\Phi 80$ mm cylindrical object, you can choose either one of pitch setting. You can get more consistent result with the Wide setting.

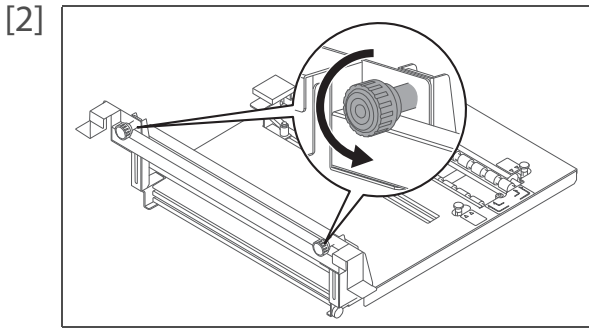

Loosen the thumbscrews (x2) to unlock the attachment.

- Check that the attachment can slide up and down smoothly.

 **Note**

Rotate the thumbscrews more than half a turn.
Be careful not to loosen too much.

[3] Open the front cover.

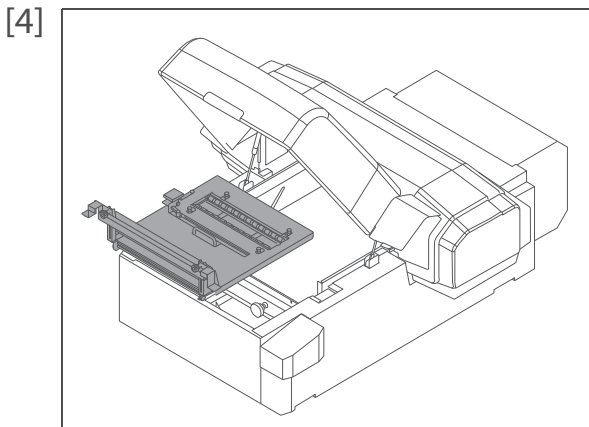

Install the Rotary Unit in the printer.

 **Important!**

**When installing Rotary Unit, be careful not to hit the inside of printer.
It may affect print quality.**

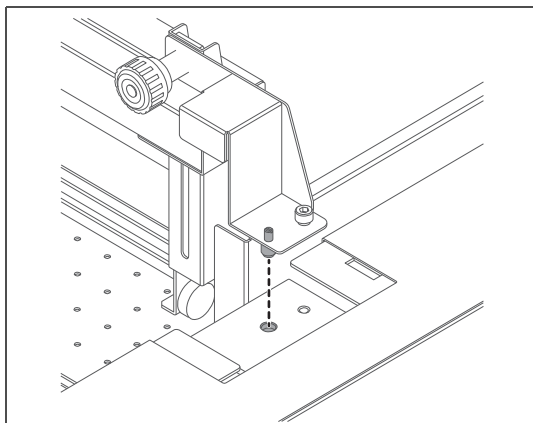

- Align the registration pin on the Rotary Unit with the hole on the printer and insert it.

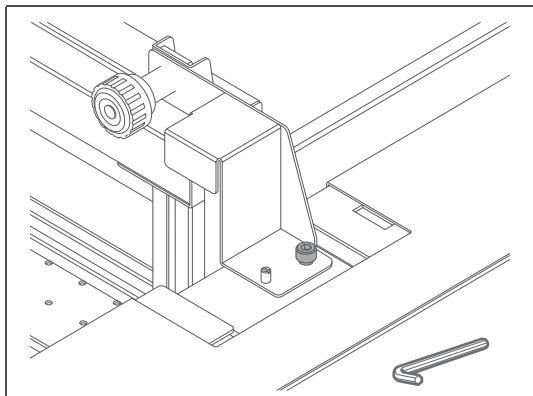

- First, tighten the screw on the right side of Rotary Unit using the hex wrench supplied with the Rotary Unit.
- Then, tighten the other side of screw.

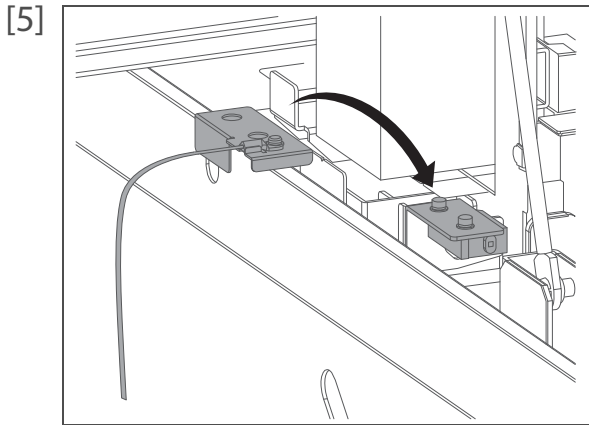

Attach the unit detection plate to the obstacle detection sensor.

- Make sure that the wire of the plate does not get twisted.

 **Note**

Make sure to attach the unit detection plate to the obstacle detection sensor. If not, an error message will appear on the operation panel and you will not be able to move on to the next step.

[6] Close the front cover.

[7]

InstallRotaryUnit	-> E
--------------------------	----------------

The message on the left will appear.

- Press the [Enter] key.

[8]

Install Unit ?	No
-----------------------	-----------

Press the [-] key.

[9]

Install Unit ?	Yes
-----------------------	------------

Press the [Enter] key.

[10]

User :	Type 1
---------------	---------------

Select the "User Type", and then press the [Enter] key.

[11]

Dia. *.*.* mm / Narrow ?	
---------------------------------	--

Check that the diameter and roller pitch displayed on the panel match with the size of object you want to use.

Dia. *.*.* mm / Wide ?	
-------------------------------	--

- To change the settings, press the [Cancel] key.
- If correct, press the [Enter] key and go to step 13.

 **Note**

Depending on the settings in the selected user type, the appropriate message appears.

[12]

Diameter:	** mm
------------------	--------------

Input the diameter of the object and then press the [Enter] key.

RollerPitch:	Wide
---------------------	-------------

When the media diameter entered is between 60.0 and 80.0 mm, use [+] or [-] key to select the roller pitch setting, then press the [Enter] key.

RollerPitch:	Narrow
---------------------	---------------

 **Note**

You can get more consistent result with the "Wide" setting.

[13]

Adj. PitchToWide -> E

Adj. PitchToNarrow -> E

Follow the instruction on the operation panel to change the roller pitch on the Rotary Unit.

- Press the [Enter] key, and then open the front cover.

Adjust the roller pitch.

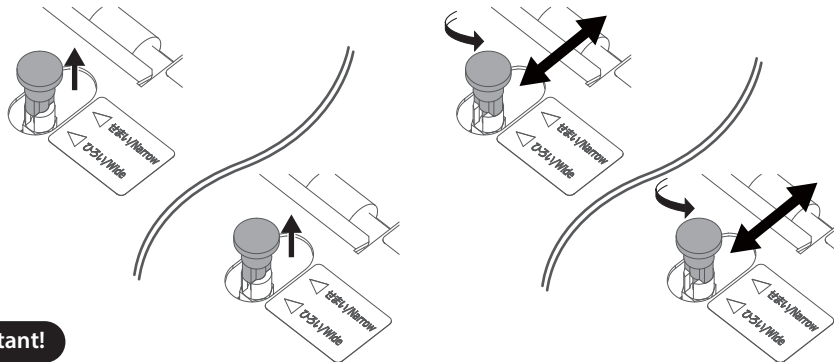

Important!

When changing the roller pitch, always slide the right and left knobs per roller at a time. Do NOT slide one knob only or two knobs separately. The roller cannot move correctly.

[14] Close the front cover, and then press the [Enter] key.

[15]

AdjustRollerPitch ? No

Press the [-] key.

[16]

AdjustRollerPitch ? Yes

Press the [Enter] key.

[17]

LoosenThumbScrew -> E

The message on the left will appear.

- Open the front cover of the printer.

[18]

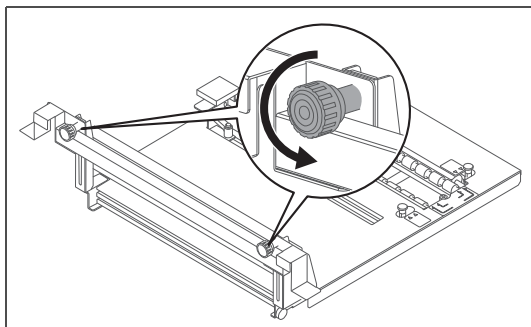

Loosen the thumbscrews (x2) to unlock the attachment.

- After ensuring that both thumbscrews are loosened, close the front cover and press the [Enter] key.

Note

- Rotate the thumbscrews more than half a turn. Be careful not to loosen too much.
- For simplicity, the printer body is excluded in this illustration.

[19]

LoosenThumbScrew? N

Press the [-] key.

[20]

LoosenThumbScrew? Y

Press the [Enter] key.

Wait for a while

The table moves to the appropriate height.

TightenThumbScrew -> E

The message on the left will appear.

- Open the front cover of the printer.

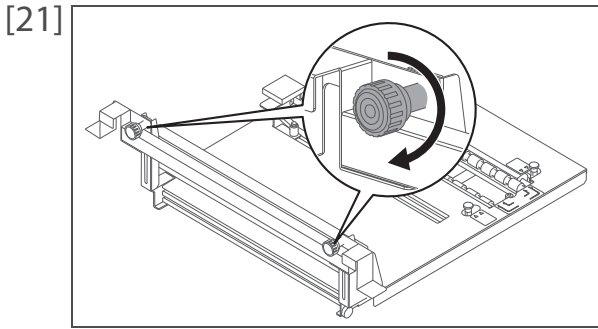

Tighten the thumbscrews until the attachment is locked.

- After ensuring that the thumbscrews on both left and right are tightened, close the front cover and press the [Enter] key.

 **Note**

- Do NOT tighten too much. It causes damage to the Rotary Unit.
- For simplicity, the printer body is excluded in this illustration.

[22]

TightenThumbScrew?	N
---------------------------	----------

Press the [-] key.

[23]

TightenThumbScrew?	Y
---------------------------	----------

Press the [Enter] key.

Set media, then

press Set Media key.

- Now, the Rotary Unit is installed in the printer.

Nozzle check and cleaning

By using the dummy table supplied with the rotary unit, you can run a nozzle check with the rotary unit installed.

Before starting everyday operation, please perform nozzle check printing to check the print head condition. If nozzle clog is found, perform cleaning.

This printer offers the following four kinds of nozzle checks:

- Nozzle Check R: Print the nozzle check pattern by the nozzles used for Rotary Mode.
- Nozzle Check RB: Print the "Nozzle Check R" pattern on the partially colored background.
- Nozzle Check: Print the normal nozzle check pattern (print the pattern by using all nozzles).
- Nozzle Check B: Print the "Nozzle Check" pattern on the partially colored background.

Note

- When printing on VJ-626UF using the rotary unit, it is recommended to select Nozzle Check R or Nozzle Check RB to run a nozzle check.
- "Nozzle Check RB" and "Nozzle Check B" will only appear in the menu if the printer is set to 6-color configuration.
- If you are using Rotary Unit on the printer other than VJ-626UF, see the relevant operation manual for panel operation.

 ["About the operation manual" P.3](#)

Required Items:



- Dummy Table
- Media for nozzle check
(Maximum media size: width 480 mm × length 70 mm, Maximum media thickness: 0.3 mm)
- Scotch tape or masking tape

Note

- When using white ink, colored media, transparent films or semi-transparent films (such as OHP film, tracing paper and more) are recommended to use for nozzle check.
- The minimum media size for nozzle check printing is (W) 280 mm x (L) 35 mm.
Depending the nozzle check pattern, the printer may leave blank space.
- You can print the nozzle check pattern twice without replacing media.
To run the second nozzle check print on the same media, you need at least (W) 280 mm x (L) 70 mm media.
- When loading media on the dummy table, make sure to place it on the table without slant.

1. Nozzle check steps

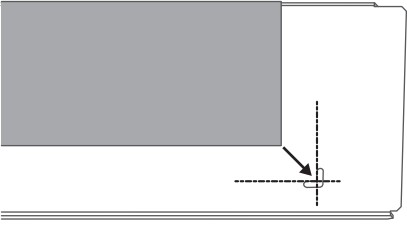
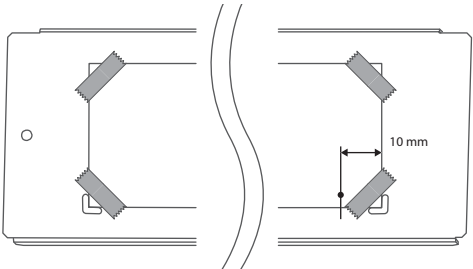

Place media on the dummy table

- [1] 
- Align the corner of media with the inner side of L-shaped registration hole on the dummy table and place it on the table.
- [2] 
- Using scotch tape or masking tape, tape each corner of the media in place.
-  **Note**
When printing the nozzle check pattern, the printer leaves 10 mm margin in right side.
Make sure that the tape does not cover the print start position.

Important!

**Make sure to sit the media flat on the dummy table without warps.
If not, it can cause the head strike and you may not print the nozzle check pattern correctly.**

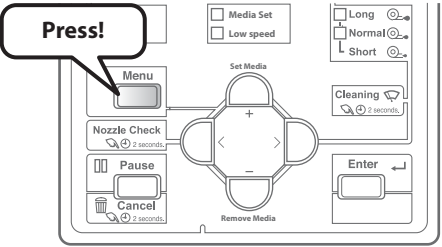
Install the dummy table

- [1] 
- Press the [Menu] key.
-  **Note**
When pressing the [<] key for more than two seconds, the printer automatically selects Nozzle Check R and skips Step 2 through Step 4. Then the menu will move to Step 5.
- [2]

Menu1:	Setup >
---------------	-------------------

The message on the left will appear.
- Press the [-] key.
- [3]

Menu2:	Test Print >
---------------	------------------------

Press the [>] key.
- [4]

Test 1:	NozzleCheck R
Test 2:	NozzleCheck RB
Test 3:	NozzleCheck
Test 4:	NozzleCheck B

The selection menu of nozzle check pattern will appear.
- Use the [+] / [-] key to select the pattern, and then press the [Enter] key.

[5]

Execute Menu?	No
----------------------	-----------

Press the [-] key.

[6]

Execute Menu?	Yes
----------------------	------------

Press the [Enter] key.

Wait for a while

The table moves to the front side of the printer.

[7]

Remove Media	-> Enter
---------------------	--------------------

Remove the media on the table, and then press the [Enter] key.

 **Note**

If the printer is set to any of the following settings, Step 8 through Step 14 are skipped. You can go to the Step 15.

- Roller Pitch setting is set to "Narrow" and Diameter setting is set to 76.0 mm or more.
- Roller Pitch setting is set to "Wide" and Diameter setting is set to 83.8 mm or more.

[8]

LoosenThumbScrew	-> E
-------------------------	----------------

The message on the left will appear.

- Open the front cover of the printer.

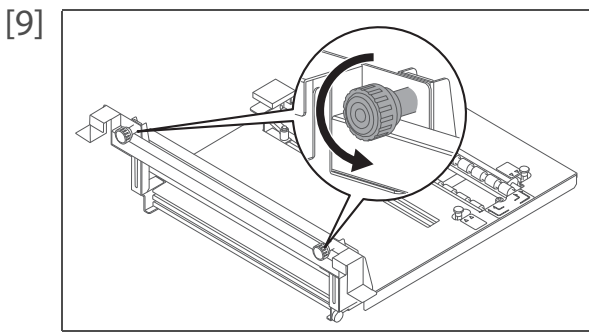

Loosen the thumbscrews (x2) to unlock the attachment.

- After ensuring that both thumbscrews are loosened, close the front cover and press the [Enter] key.

 **Note**

- Rotate the thumbscrews more than half a turn. Be careful not to loosen too much.
- For simplicity, the printer body is excluded in this illustration.

[10]

LoosenThumbScrew?	N
--------------------------	----------

Press the [-] key.

[11]

LoosenThumbScrew?	Y
--------------------------	----------

Press the [Enter] key.

Wait for a while

The table moves to the appropriate height for nozzle check printing.

TightenThumbScrew	-> E
--------------------------	----------------

The message on the left will appear.

- Open the front cover of the printer.

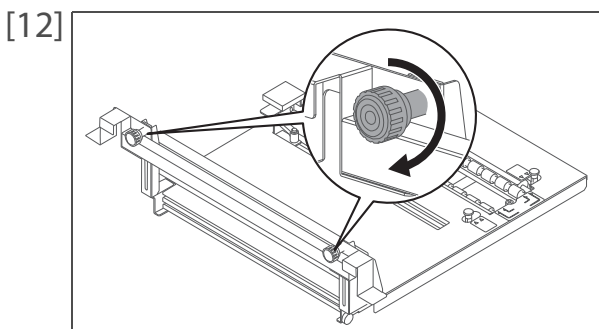

Tighten the thumbscrews until the attachment is locked.

- After ensuring that the thumbscrews on both left and right are tightened, close the front cover and press the [Enter] key.

 **Note**

- Do NOT tighten too much. It causes damage to the Rotary Unit.
- For simplicity, the printer body is excluded in this illustration.

[13]

TightenThumbScrew?	N
--------------------	---

Press the [-] key.

[14]

TightenThumbScrew?	Y
--------------------	---

Press the [Enter] key.

Wait for a while

The table moves to the installation position of dummy table.

[15]

Install Dummy Table	-> E
---------------------	------

The message on the left will appear.

- Open the front cover of the printer.

[16] Install the dummy table.

- Fit the L angle of the dummy table into the gap of the printer to place it on the printer.
- Close the front cover, and then press the [Enter] key.

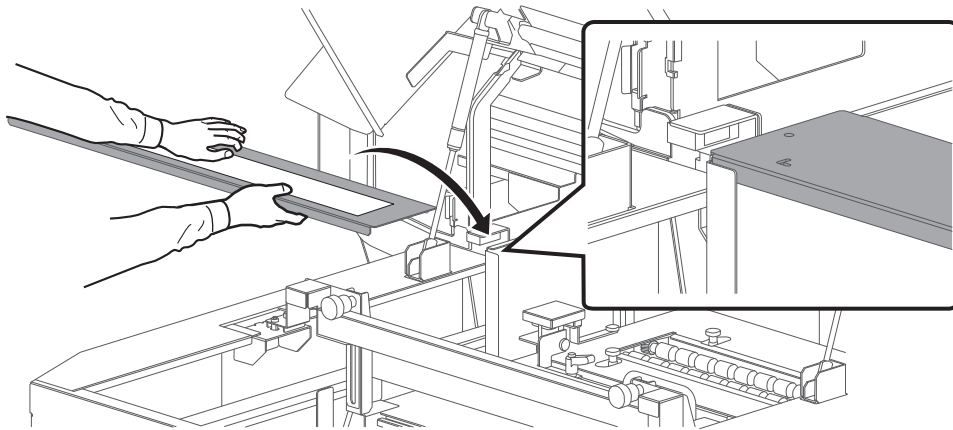

Important!

When installing / removing the dummy table, do not touch or pull the wire of unit detection plate.

[17]

Install Table ?	No
-----------------	----

Press the [-] key.

[18]

Install Table ?	Yes
-----------------	-----

Press the [Enter] key.

Printing

Nozzle check patterns will be printed.

Wait for a while

The table moves to the front side of the printer.

[19]

NozzleCHK1:	Cleaning
-------------	----------

The message on the left will appear.

- Open the front cover, and then check the nozzle check pattern.

2. Check the nozzle check print and perform cleaning

Check the Nozzle check pattern

[1]

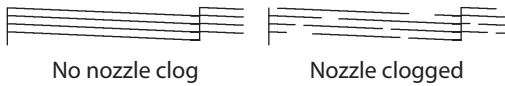

Check the nozzle check print.

- If the print showed missing nozzles, go to the ["Perform Cleaning" P.19.](#)
- If the print showed no missing nozzles, end the nozzle check.
👉 ["End the nozzle check" P.22](#)



When performing nozzle check RB, part of the nozzle check pattern background is black (part of the white pattern).



Note

- For the CMYK nozzles, the background is printed in white ink.
- For varnish (and part of white) nozzles, the background is not printed.



Note

- The figure below are examples of the Nozzle Check R patterns.
- The printer information (date and time of printing, printer's serial number, firmware version) is printed on the nozzle check pattern.

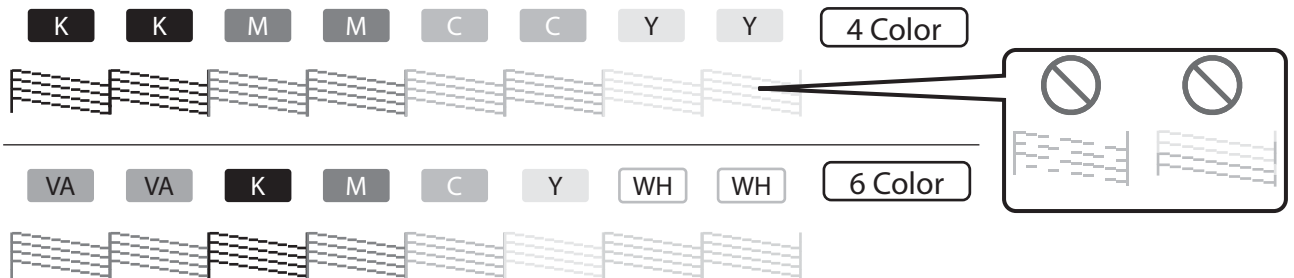

- The figure below is an example of the Nozzle Check RB pattern. In this example, non-colored background area is shown in gray.

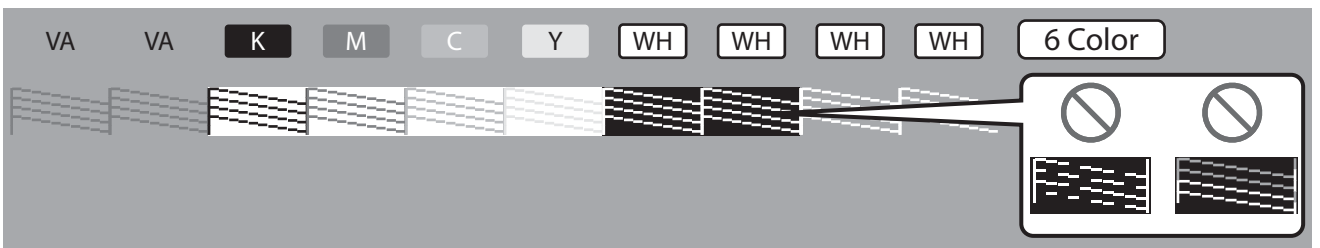

Perform Cleaning

[1] Close the front cover.

[2]

NozzleCHK1:	Cleaning
--------------------	-----------------

The message on the left will appear.

- Press the [Enter] key.

[3]

Time 1:	Short
----------------	--------------

Select the cleaning mode.

- Use the [+] / [-] key to select, and then press the [Enter] key.

Time 2:	Normal
----------------	---------------

Time 3:	Long
----------------	-------------

Time 4:	Little Charge
----------------	----------------------

Time 5:	Initial Charge
----------------	-----------------------

Cleaning	**%
-----------------	------------

Cleaning will start.



Note

- If you select "Initial Charge", the message "Empty WasteInk -> E" will appear. Follow the instructions on the VJ-626UF Operation Manual to drain all waste fluid in the waste ink tank into a container (e.g. PET bottle). After emptying the waste ink tank, make sure to reset the waste ink counter.
 VJ-626UF Operation Manual "Emptying waste ink tank"
- If you select "Little Charge" or "Initial Charge", the message "Ink Charge **%" will be displayed.

[4]

NozzleCHK2:	Print
--------------------	--------------

When head cleaning ends, the message on the left will appear.

Run the second nozzle check print on the same media

[1]

NozzleCHK2:	Print
-------------	-------

Press the [Enter] key.

[2]

Print 1 :	NozzleCheck R
Print 2 :	NozzleCheck RB
Print 3 :	NozzleCheck
Print 4 :	NozzleCheck B

The selection menu of nozzle check pattern will appear.

- Use the [+] / [-] key to select the pattern, and then press the [Enter] key.

Important!

Before selecting nozzle check pattern, check that the media on the dummy table has enough space.

To run the second nozzle check print on the same media, at least (W) 280 mm x (L) 70 mm media is needed.

If the media size is not enough, the pattern will be printed on the dummy table.

Printing

Nozzle check patterns will be printed.



Wait for a while

The table moves to the front side of the printer.

[3]

NozzleCHK1:	Cleaning
-------------	----------

The message on the left will appear.

- Open the front cover, and then check the nozzle check pattern.
 ["Check the Nozzle check pattern" P.18](#)
- If the print showed no missing nozzles, end the nozzle check.
 ["End the nozzle check" P.22](#)

To run the third nozzle check print

The printer can run up to "two" nozzle check prints on the same media.

If you want to run a nozzle check one more time, follow the steps below to place a new media on the dummy table.

[1]

NozzleCHK2:	Print
-------------	-------

Press the [Enter] key.

[2]

Print 1 :	NozzleCheck R
Print 2 :	NozzleCheck RB
Print 3 :	NozzleCheck
Print 4 :	NozzleCheck B

The selection menu of nozzle check pattern will appear.

- Use the [+] / [-] key to select the pattern, and then press the [Enter] key.

- [3] **Load Media for NzChk**
- The message on the left will appear.
- Open the front cover, and then remove the media.
 - Place the new media on the dummy table, and then close the front cover
-  ["Place media on the dummy table" P.15](#)

- [4] Press the [Set Media] key.

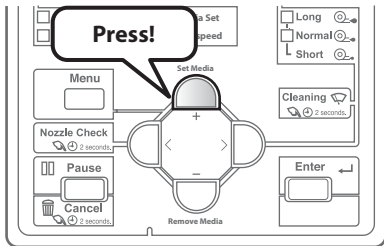

Wait for a while

The message on the left will appear.

Printing

Nozzle check patterns will be printed.

Wait for a while

The table moves to the front side of the printer.

- [5] **NozzleCHK1: Cleaning**

- The message on the left will appear.
- Open the front cover, and then check the nozzle check pattern.
-  ["Check the Nozzle check pattern" P.18](#)

3. End the nozzle check

Remove the dummy table

[1] To end the nozzle check, press the [Cancel] key.

NozzleCHK1: Cleaning

[2] The message on the left will appear.

Remove Dummy Table -> E

- Open the front cover of the printer.

[3] Remove the dummy table.

- Close the front cover, and then press the [Enter] key.

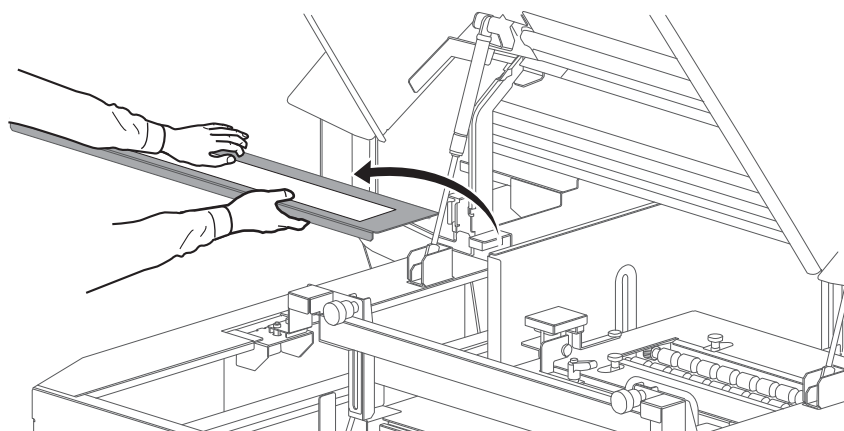

Important!

When installing / removing the dummy table, do not touch or pull the wire of unit detection plate.

[4] Press the [-] key.

Remove Table ? No

[5] Press the [Enter] key.

Remove Table ? Yes

The message on the left will appear.

Wait for a while

Move the table to original height

Note

If the printer is set to any of the following settings, you can skip this procedure and start printing.

- Roller Pitch setting is set to "Narrow" and Diameter setting is set to 76.0 mm or more.
- Roller Pitch setting is set to "Wide" and Diameter setting is set to 83.8 mm or more.

[1] **LoosenThumbScrew** **-> E**

The message on the left will appear.

- Open the front cover of the printer.

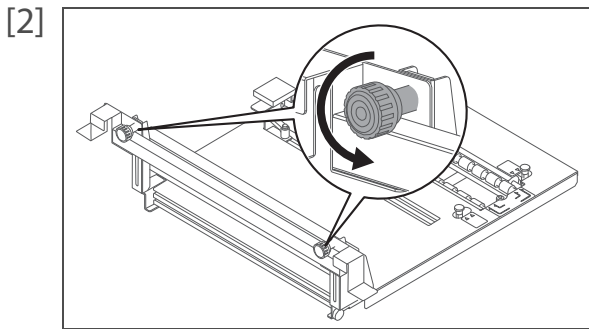

Loosen the thumbscrews (x2) to unlock the attachment.

- After ensuring that both thumbscrews are loosened, close the front cover and press the [Enter] key.

Note

- Rotate the thumbscrews more than half a turn. Be careful not to loosen too much.
- For simplicity, the printer body is excluded in this illustration.

[3] **LoosenThumbScrew?** **N**

Press the [-] key.

[4] **LoosenThumbScrew?** **Y**

Press the [Enter] key.

Wait for a while

The table moves to the original height before the nozzle check.

TightenThumbScrew **-> E**

The message on the left will appear.

- Open the front cover of the printer.

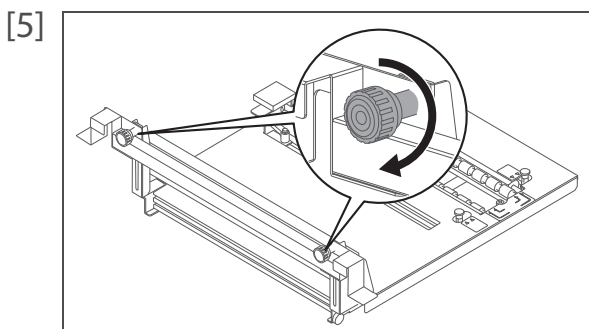

Tighten the thumbscrews until the attachment is locked.

- After ensuring that the thumbscrews on both left and right are tightened, close the front cover and press the [Enter] key.

Note

- Do NOT tighten too much. It causes damage to the Rotary Unit.
- For simplicity, the printer body is excluded in this illustration.

[6] **TightenThumbScrew?** **N**

Press the [-] key.

[7] **TightenThumbScrew?** **Y**

Press the [Enter] key.

Set media, then

press Set Media key.

- The nozzle check ends.

Loading the media

Note

If you are using Rotary Unit on the printer other than VJ-626UF, see the relevant operation manual for panel operation.

["About the operation manual" P.3](#)

Select Print Settings

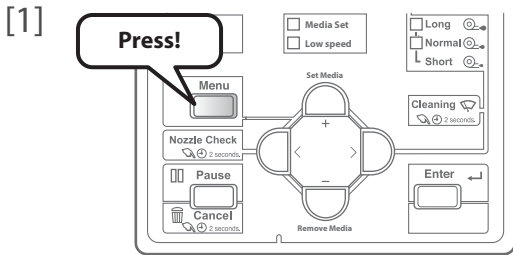

Press the [Menu] key.

Note

Long press the [Set Media] key for more than 2 seconds to move to "Media 3: Height" setting menu. You can go to the Step 8.

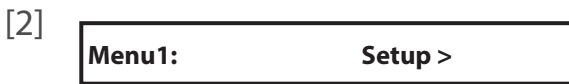

Press the [>] key.



Press the [Enter] key.



Select the "User Type", and then press the [Enter] key.



To change the "Print Mode", press the [Enter] key.



Select the print mode.

Use the [+] / [-] key to select, and then press the [Enter] key.



Note

When using Rotary Unit, the printer always prints at 720 x 1080 print resolution. You cannot change the print resolution by print mode setting.

- "Print Mode: Balanced"
Balanced mode of high quality print and quick print time.
- "Print Mode: Fast"
Select this mode for high speed printing. Print quality might be reduced.
- "Print Mode: Fine"
Select this mode for high quality printing. Printing speed would be reduced.
This mode can be effective for small diameter objects to improve print quality.



Press the [-] key several times, to bring up the display on the left.

- Press the [>] key.



Press the [-] key several times, to bring up the display on the left.

- Press the [Enter] key.

[8]

Diameter:	** mm
-----------	-------

Input the diameter of the object and then press the [Enter] key.

RollerPitch:	Wide
--------------	------

When the media diameter entered is between 60.0 and 80.0 mm, use [+] or [-] key to select the roller pitch setting, then press the [Enter] key.

RollerPitch:	Narrow
--------------	--------

 **Note**

You can get more consistent result with the "Wide" setting.

Wait for a while

The message on the left will appear.

[9]

Remove Media	-> Enter
--------------	----------

Press the [Enter] key.

[10]

Adj. PitchToWide	-> E
------------------	------

Follow the instruction on the operation panel to change the roller pitch on the Rotary Unit.

Adj. PitchToNarrow	-> E
--------------------	------

- Press the [Enter] key, and then open the front cover.

 **Note**

Depending on the media diameter entered in the Step 8, the appropriate instruction will display on the panel.

Adjust the roller pitch.

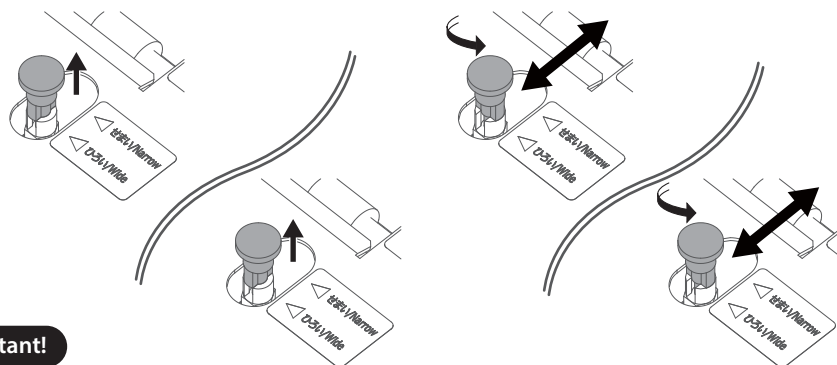

 **Important!**

When changing the roller pitch, always slide the right and left knobs per roller at a time. Do NOT slide one knob only or two knobs separately. The roller cannot move correctly.

[11] Close the front cover, and then press the [Enter] key.

[12]

AdjustRollerPitch ?	No
---------------------	----

Press the [-] key.

[13]

AdjustRollerPitch ?	Yes
---------------------	-----

Press the [Enter] key.

LoosenThumbScrew	-> E
------------------	------

The message on the left will appear.

- Open the front cover of the printer.

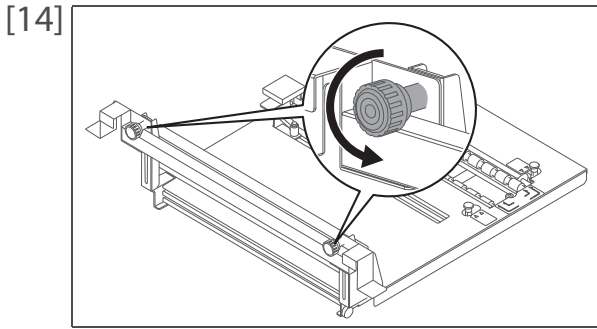

Loosen the thumbscrews (x2) to unlock the attachment.

- After ensuring that both thumbscrews are loosened, close the front cover and press the [Enter] key.

Note

- Rotate the thumbscrews more than half a turn. Be careful not to loosen too much.
- For simplicity, the printer body is excluded in this illustration.

[15] **LoosenThumbScrew? N**

Press the [-] key.

[16] **LoosenThumbScrew? Y**

Press the [Enter] key.

Wait for a while

The table moves to the appropriate height.

TightenThumbScrew -> E

The message on the left will appear.

- Open the front cover of the printer.

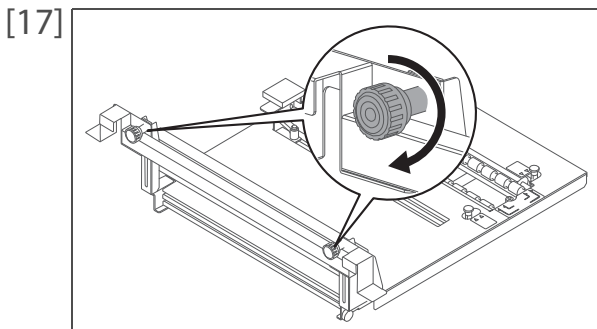

Tighten the thumbscrews until the attachment is locked.

- After ensuring that the thumbscrews on both left and right are tightened, close the front cover and press the [Enter] key.

Note

- Do NOT tighten too much. It causes damage to the Rotary Unit.
- For simplicity, the printer body is excluded in this illustration.

[18] **TightenThumbScrew? N**

Press the [-] key.

[19] **TightenThumbScrew? Y**

Press the [Enter] key.

Set media, then

- The next step is to load a cylindrical object.

press Set Media key.

Loading the media

[1] Open the front cover.

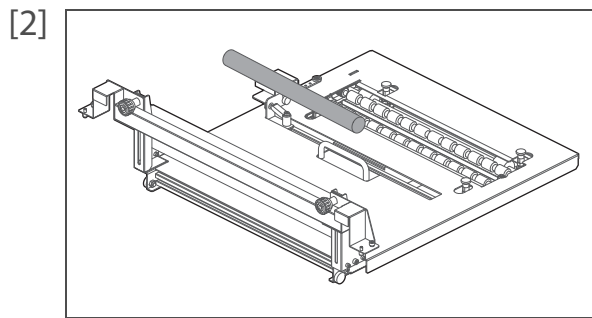

Load a cylindrical object on the Rotary Unit.

 Note

For simplicity, the printer body is excluded in this illustration.

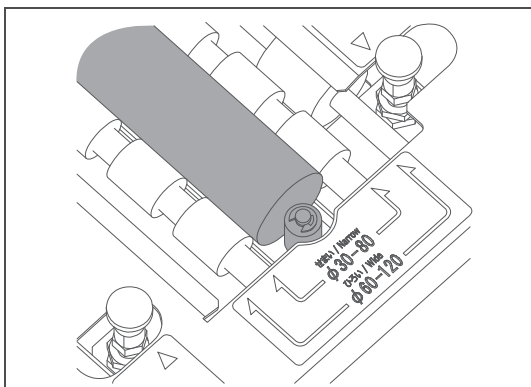

Align the edge of the object with the media registration pin.

 Note

Please see "[Origin of image on Layout and Print Tool 2 and print start position](#)" P.34, and place it on the Unit correctly.

 Note

If a cylindrical object does not stay on the rollers, use the media retainer to hold it on the rollers.

- Depending on the shape of object, the media retainer cannot hold the object properly.
- If you are using lightweight object, the object might be lifted by the media retainer. In such cases, do not use the media retainer.

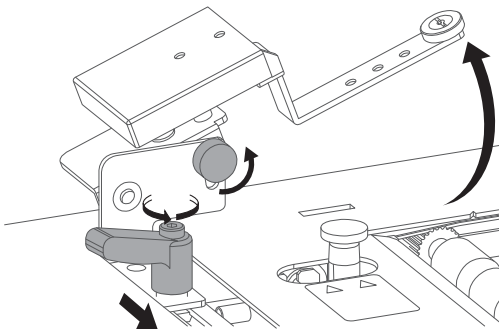

<How to adjust the media retainer>

- Use the position adjustment lever to change the position of media retainer.
- Use the angle adjustment knob to change the angle of media retainer.

- [3] Put the right side of the guide bar on the guide plate and place in on the printer as shown below to check the following points:
- Make sure that the object does not touch the guide bar.
 - Check that the gap between the object and guide bar is not too large.

Important!

If the gap between the print head and object is not adequate, measure the diameter of the object again and input the correct diameter.

Otherwise, it can damage the print head, causing printing failure.

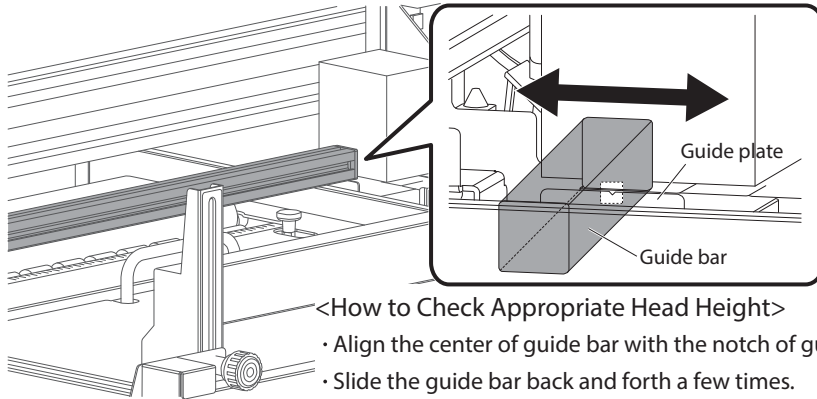

- [4] Close the front cover.

- [5]

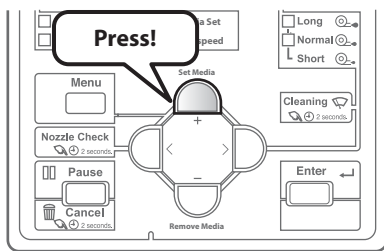

Press the [Set Media] key.

- [6]



Press the [Enter] key.

Note

- This menu only appears when the User Type are selected for the first time.
- If you select "On", you will have to input the "Media size", "Media location" and "Media origin" after pressing the [Set Media] key each time you set a media on the table.
- If you select "Off" via the [-] key, "Ready to Print" will be displayed after pressing the [Set Media] key each time you set a media on the table. In that case, the currently selected User Type values will be used for the "Media size", "Media location" and "Media origin".

1. Inputting the media width and length

[1]

Width:	360 mm
---------------	---------------

Use the [+] / [-] key to input the media width.
Press the [Enter] key.

 **Note**

- Any value from 30 mm to 360 mm can be set for the width.
- If you use 360 mm width media, you cannot input a Y-direction value for the set position.

[2]

Length:	405 mm
----------------	---------------

Use the [+] / [-] key to input the media length.
Press the [Enter] key.

 **Note**

- Any value from 30 mm to 405 mm can be set for the length.
- If you use 405 mm length media, you cannot input an X-direction value for the set position.

 **Note**

- If you entered the maximum media size (W: 360 mm, L: 405 mm), the message "MediaSize [Max.]" will appear on the panel. Then, two seconds later or after pressing the [Enter] key, the message "Confirm SET Pos. ? No" will appear. To skip the "2. Inputting the set position" step, press the [Enter] key on the message.
- If you want to check the media loading position on the table, use [-] key to select "Confirm SET Pos.? Yes", and then press the [Enter] key.

2. Inputting the set position

[1]

SET	X:	0.0	Y:	0.0
------------	-----------	------------	-----------	------------

Press the [Enter] key.

 **Note**

- If you know the media set position in advance, you can input it here, using the [+] / [-] key to enter the X (longitudinal) value and [<] / [>] key to enter the Y (lateral) value.
- For the set position, any value from 0.0 to 385.0 can be set for the X value, and any value from 0.0 to 330.0 for the Y value.
*These ranges will vary depending on the values set for the media width and length.

Moving Location Pos.

The carriage will move to the set position, with its LED pointer lit steady.

[2]

SET	X:	10.0	Y:	20.0
------------	-----------	-------------	-----------	-------------

Use the keys to align the LED pointer with right front corner of the media.

- Use the [+] / [-] key to move the table forward/backward.
 - Use the [<] / [>] key to move the LED pointer leftward/rightward.
- Press the [Enter] key to set the position.

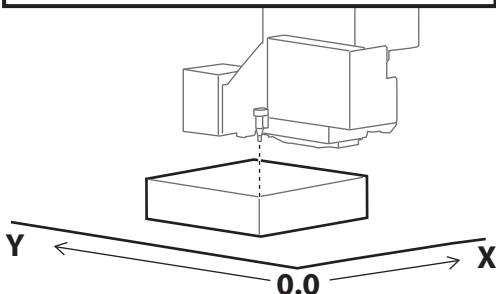

3. Inputting the origin position

[1]

Origin: On

Press the [Enter] key.



Note

If you select "Off", the origin setting in the User Type will be X = 0.0, Y = 5.0.



Note

- If you entered the minimum media size (W: 30 mm, L: 20 mm), the message "MediaSize [Min.]" will appear on the panel. Then, two seconds later or after pressing the [Enter] key, the message "Confirm ORG Pos. ? No" will appear. You can skip the origin position confirmation by pressing the [Enter] key. The origin is set to X: 0.0, Y: 5.0.
- If you want to check the origin position on the media, use the [-] key to select "Confirm ORG Pos. ? Yes", and then press the [Enter] key.

[2]

ORG X: 0.0 Y: 5.0

Press the [Enter] key.



Note

- If you know the print origin position in advance, you can input it here, using the [+] / [-] key to enter the X (longitudinal) value and [<] / [>] key to enter the Y (lateral) value.
- For the origin position, any value from 0.0 to 385.0 for the X value, and any value from 5.0 to 335.0 for the Y value, can be entered.
*These ranges will vary depending on the values set for the media width and length.

Moving Origin Pos.

The carriage will move to the set position, with its LED pointer lit steady.

[3]

ORG X: 15.0 Y: 40.0

Use the keys to move the LED pointer to the origin position (print start point).

- Use the [+] / [-] key to move the table forward/backward.
- Use the [<] / [>] key to move the LED pointer leftward/rightward. Press the [Enter] key to set the position.

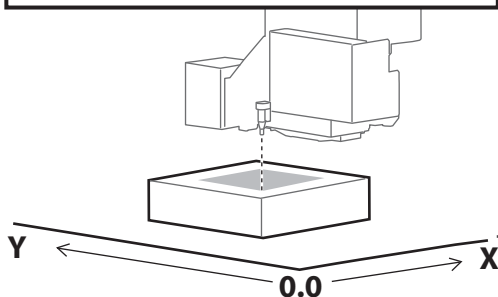

Ready to Print

That completes setting of the media.



Note

To display the input menu for "Media size", "Media location" and "Media origin", long press the [Enter] key for more than 2 seconds while "Ready to Print" is displayed.

Any values you input will be reflected in the currently selected User Type.

Change the User Type

To print on other round object with different diameter size, select an appropriate user type (from Type 1 to Type 10). When changing the user type, you can also change the diameter or roller pitch setting in the selected user type.

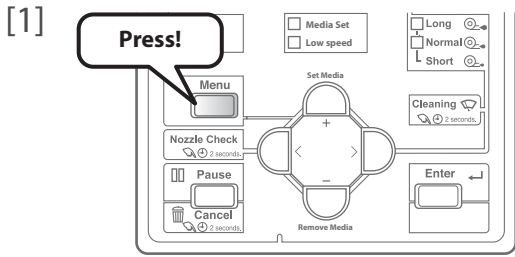

Press the [Menu] key.

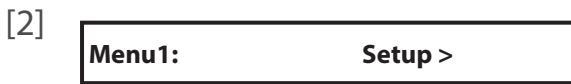

Press the [>] key.

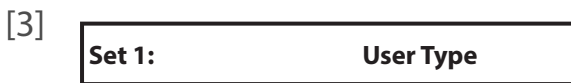

Press the [Enter] key.



Select the user type you want to use, and then press the [Enter] key.



Check that the diameter and roller pitch displayed on the panel match with the size of object you want to use.



- To change the settings, press the [Cancel] key.
- If correct, press the [Enter] key and go to step 7.

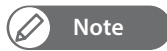

Note

Depending on the settings in the selected user type, the appropriate message appears.

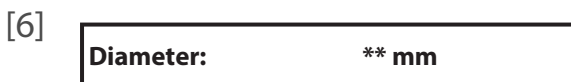

Input the diameter of the object and then press the [Enter] key.



When the media diameter entered is between 60.0 and 80.0 mm, use [+] or [-] key to select the roller pitch setting, then press the [Enter] key.

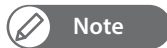

Note

You can get more consistent result with the "Wide" setting.

[7] The user type is saved with the specified diameter and roller pitch settings.

- For the following procedures, see ["Select Print Settings" P.24](#) from step 9 onward.

Basic printing instructions

This section explains the basic cylindrical printing instructions using Rotary Unit.
For the detailed instruction of each application, see the operation manual of applicable application.

Required application (Supported version):

- VJ-626UF Driver (Ver. 1.02 or later)
- Layout and Print Tool 2 (Ver. 1.3.0 or later)
- ValueJet Layer Editor (Ver. 4.3.0 or later)

Note

If you are using Rotary Unit on the printer other than VJ-626UF, see the relevant operation manual for instructions on the print application.

 ["About the operation manual" P.3](#)

1. Create Print Page Layout in Layout and Print Tool 2

[1] Start Layout and Print Tool 2.

Note

Step 2 through Step 4 appears when you start Layout and Print Tool 2 for the first time.

[2]

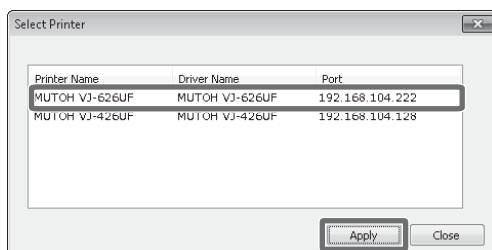

Select the printer driver.

- Click [Apply].

[3]

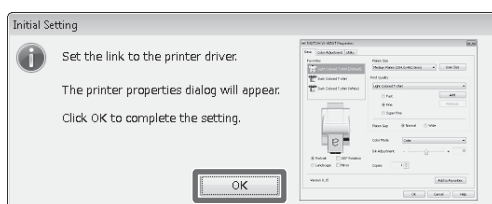

If the driver settings have not been completed, the dialog on the left will appear.

- Click [OK].

[4]

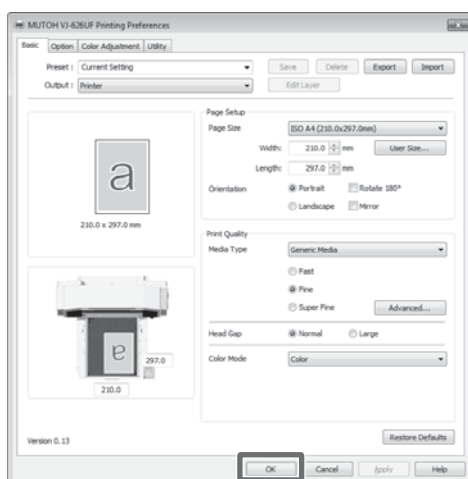

The dialog on the left will appear.

- Click [OK].

[5]

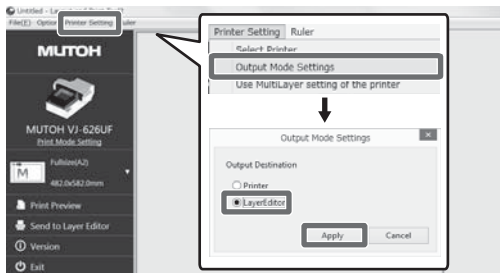

Select the output destination.

- Click [Printer Setting].
- Click [Output Mode Settings].
- Select [Layer Editor], and then click [Apply].

[6]

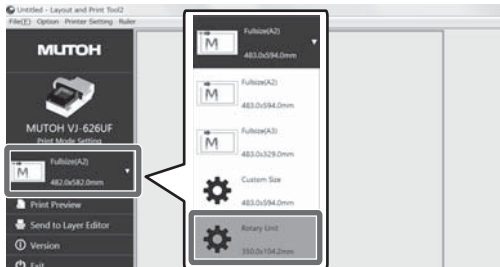

Select the type of media.

- Open the Media dropdown list.
- Click [Rotary Unit].

[7]

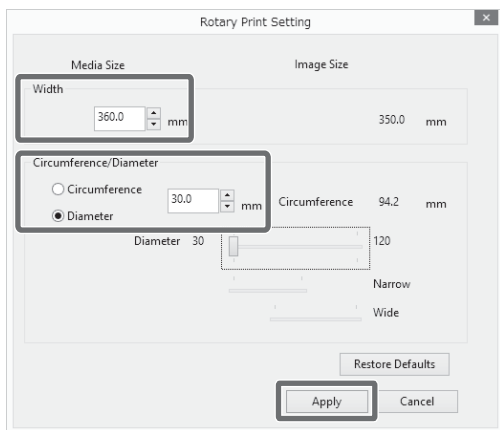

Configure media settings.

- Enter the media width.
- Enter the media diameter, or circumference.
- Click [Apply].

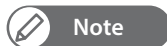

Note

- Enter the correct diameter or circumference of object as much as possible. Before loading a cylindrical object, measure the actual diameter, then place it on the Rotary Unit.
- When performing 360 degree printing, if wrong value is entered here, the seam will be thick or visible.

[8]

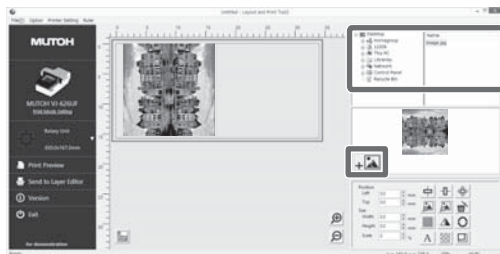

Select the image to be used in printing.

- Click the  button to insert the image.

[9]

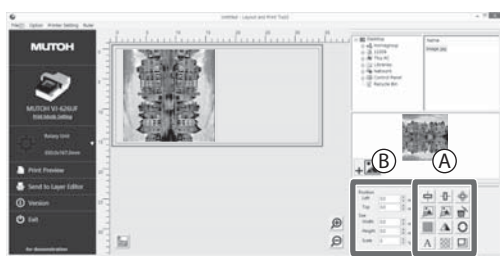

Align the image by using the following methods:

- Click the edit buttons (A on the left illustration).
- Enter values directly (B on the left illustration).

Origin of image on Layout and Print Tool 2 and print start position

The illustration below shows where the origin of image in Layout and Print Tool 2 will be printed on an object on the Rotary Unit. When creating a page layout or placing an object on the Unit, make sure that the image will be printed at the intended location.

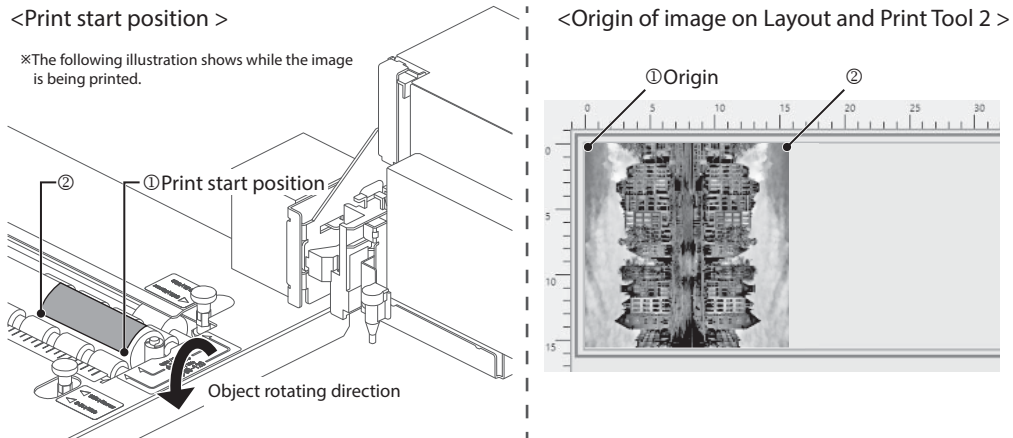

[10]

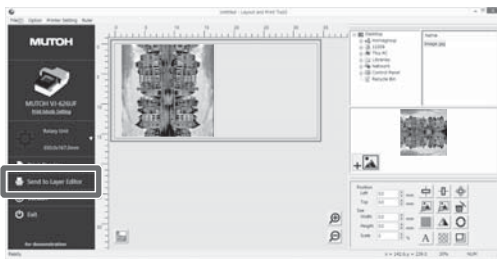

Send the print data to ValueJet Layer Editor.

- Click [Send to Layer Editor].

[11]

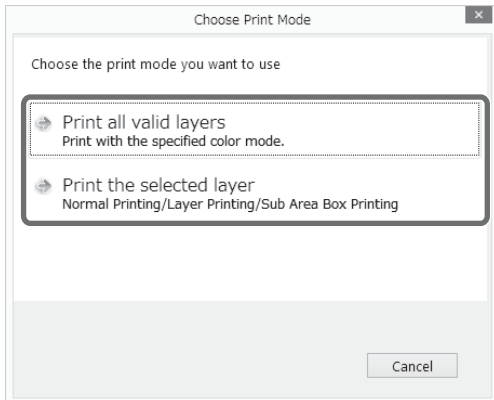

Select the Print Mode.

- Color Printing: Select [Print all valid layers].
- Layer Printing: Select [Print the selected layer].

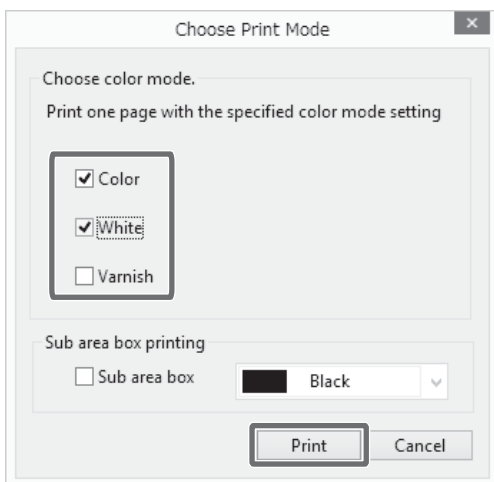

To perform layer printing, check the color mode to print the selected page.

- Click [Print].

2. Print from ValueJet Layer Editor

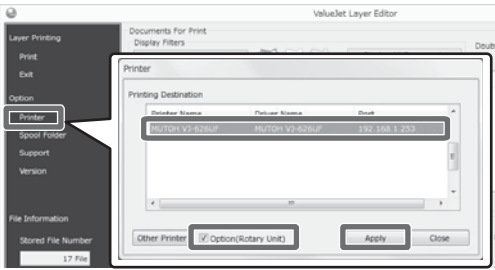
- [1] 

Select the printer.

 - Click [Printer].
 - Choose the printer that you are using.
 - Select [Option (Rotary Unit)] and then click [Apply].

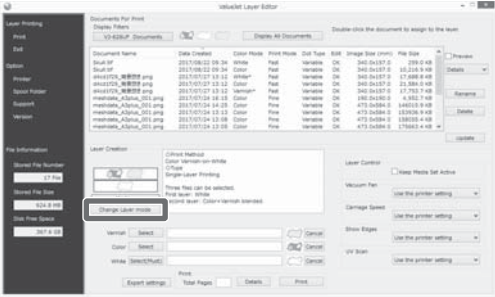
 **Note**
The printer selection dialog automatically appears when you start ValueJet Layer Editor for the first time.
- [2] 

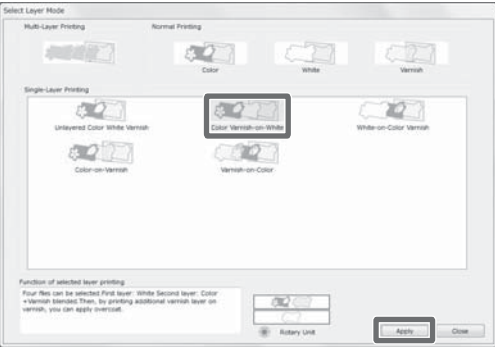
Click [Change Layer mode].
- [3] 

Configure the layer mode settings.

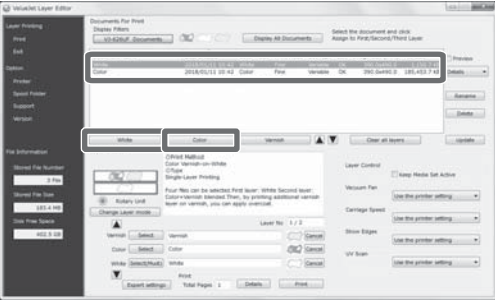
 - Select [Color Varnish on White], and then click [Apply].
- [4] 

Select two files to assign to appropriate layers.

 - From the Print Data List, click on the white file, then click "White". Next, click on the color file, then click "Color".

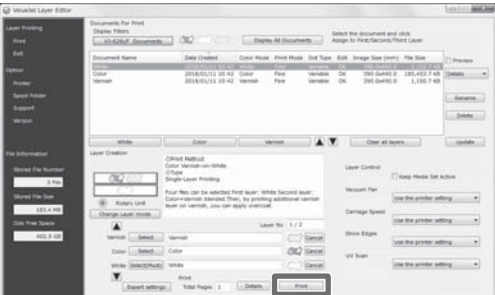
 **Note**
To see the image preview of the selected file, check Preview.
- [5] 

Start printing.

 - Confirm that the media is already loaded.
 - Click [Print].

Detaching the Rotary Unit

Note

If you are using Rotary Unit on the printer other than VJ-626UF, see the relevant operation manual for panel operation.

["About the operation manual" P.3](#)

Exit Rotary Mode

[1]

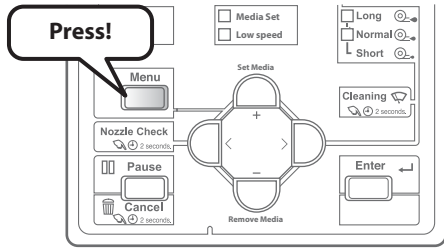

Press the [Menu] key.

- The message on the left will appear.

Menu1: Setup >

[2]

Menu5: Option >

Press the [-] key several times, to bring up the display on the left.

- Press the [>] key.

[3]

Option 1: Rotary Unit

Press the [Enter] key.

[4]

Rotary 1: RemoveUnit

Press the [Enter] key.

[5]

Execute Menu? No

Press the [-] key.

[6]

Execute Menu? Yes

Press the [Enter] key.

Wait for a while

The message on the left will appear.

[7]

Remove Media -> Enter

Remove the media on the table, and then press the [Enter] key.

[8]

RemoveRotaryUnit -> E

Remove the Rotary Unit from the printer.

Remove Rotary Unit

You will need a Phillips-head screwdriver (commercially available) and the hex wrench supplied with the printer for this procedure.

[1] Open the front cover.

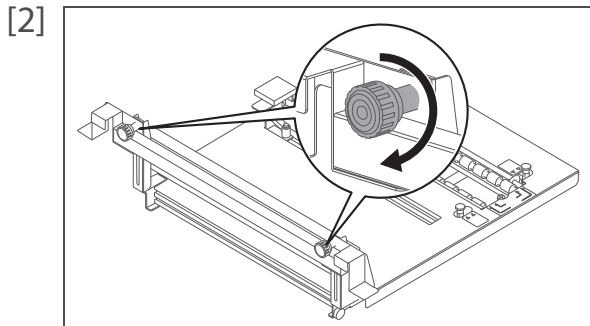

Tighten the thumbscrews until the attachment is locked.

 **Note**

- Rotate the thumbscrews more than half a turn. Be careful not to loosen too much.
- For simplicity, the printer body is excluded in this illustration.

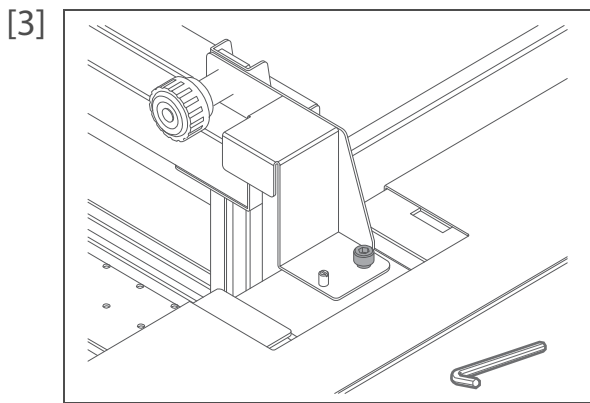

- Use the hex wrench supplied with the Unit to loosen the screw.
- Loosen the other side of screw.

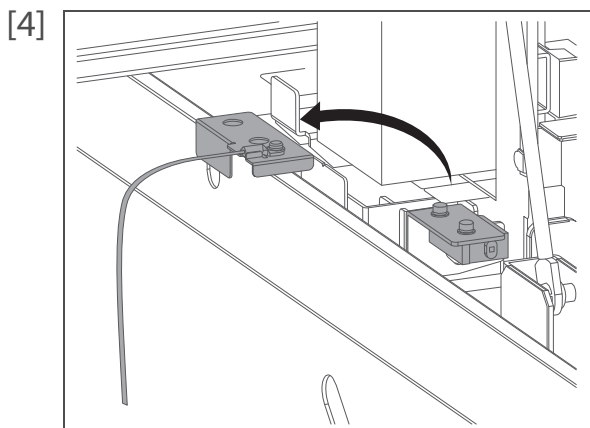

Remove the unit detection plate from the obstacle detection sensor.

 **Note**

Make sure to remove the unit detection plate from the sensor. If not, an error message will appear on the operation panel and you will not be able to move on to the next step.

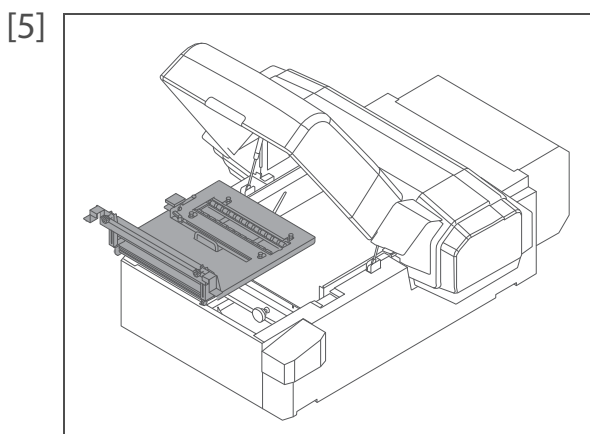

Remove the Rotary Unit from the printer.

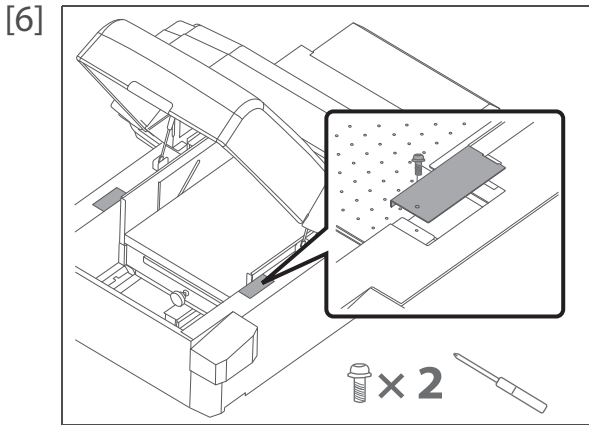

Attach the attachment covers (x2) on the printer.

- Using the Phillips-head screwdriver, tighten the screws to secure the covers to the printer.

[7] Close the front cover.

[8] **RemoveRotaryUnit** **-> E**

The message on the left will appear.

- Press the [Enter] key.

[9] **Remove Unit ?** **No**

Press the [-] key.

[10] **Remove Unit ?** **Yes**

Press the [Enter] key.

Set media, then

- Now, the Rotary Unit has been removed from the printer.

press Set Media key.

How To Correct Error After Power Off

If you need to turn off the printer due to an error requiring reboot, or you are forced to turn off the printer, follow the instruction below to correct the error. When the printer is turned off, it will automatically exit Rotary Mode.

[1]

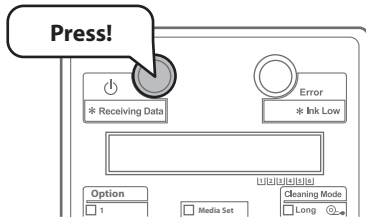

Press the power button to restart the printer.

Initializing

The message on the left will appear.

[2]

RemoveRotaryUnit -> E

Remove the Rotary Unit from the printer.

[3] Open the front cover.

[4]

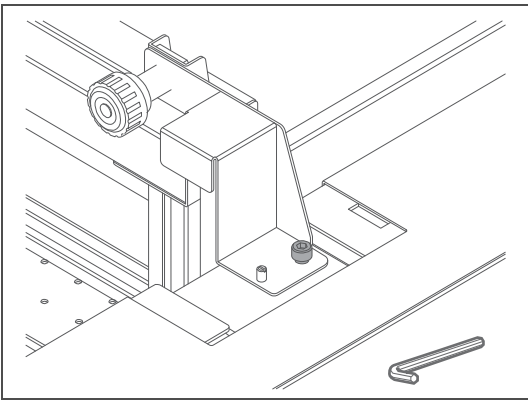

- Use the hex wrench supplied with the Unit to loosen the screw.
- Loosen the other side of screw.

[5]

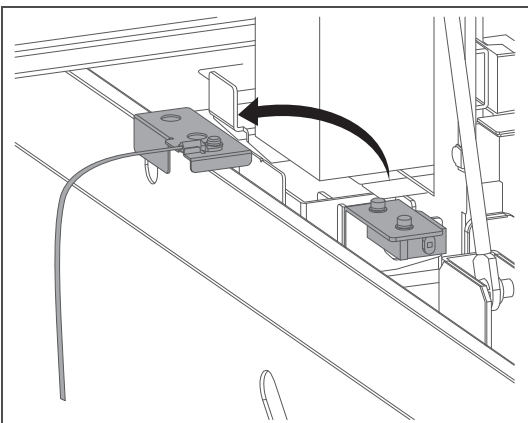

Remove the unit detection plate from the obstacle detection sensor.

 **Note**

Make sure to remove the unit detection plate from the sensor. If not, an error message will appear on the operation panel and you will not be able to move on to the next step.

[6]

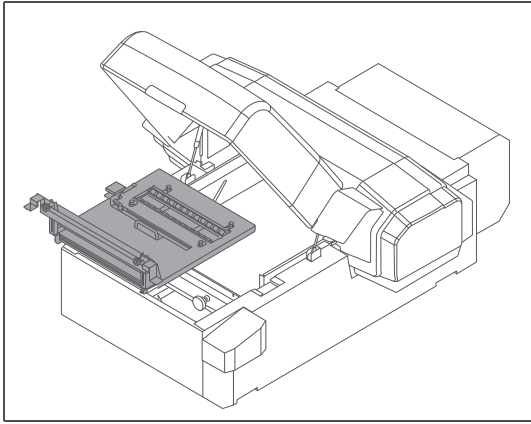

Remove the Rotary Unit from the printer.

[7]

Close the front cover.

[8]

Remove Rotary Unit	-> E
---------------------------	----------------

The message on the left will appear.

- Press the [Enter] key.

[9]

Remove Unit ?	No
----------------------	-----------

Press the [-] key.

[10]

Remove Unit ?	Yes
----------------------	------------

Press the [Enter] key.

Initializing

The message on the left will appear.

Set media, then

- Now, the Rotary Unit has been removed from the printer.

press Set Media key.

[11]

If you want to perform cylindrical printing using Rotary Unit, put the printer into Rotary Mode.

 ["Put Printer into Rotary Mode" P.7](#)

Maintenance

To maintain the performance of this product, please conduct maintenance by yourself.
The types of maintenance are shown below.

- Maintenance on Rotary Unit: Clean off the rubber on the rollers and surface of Rotary Unit.
- Maintenance on Printer: Perform a daily maintenance including print head cleaning.

Note

If you are using Rotary Unit on the printer other than VJ-626UF, see the relevant operation manual for panel operation.

 ["About the operation manual" P.3](#)

Maintenance on Rotary Unit

At the end of printing operation, follow the steps below to clean the following parts:

- Rubber parts on the roller
- Surface of Rotary Unit and instruction labels

Note

If ink already cured on the Rotary Unit, you cannot remove it with this maintenance.

Required Items:

- Soft cloth
- Neutral detergent (if needed)

[1] Open the front cover.

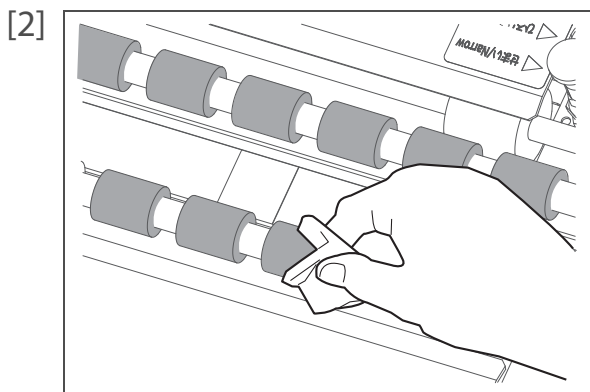

Moisten a soft cloth with water or neutral detergent diluted with water and thoroughly wring it. Use this cloth to clean off dirt on the rubber parts of rollers.

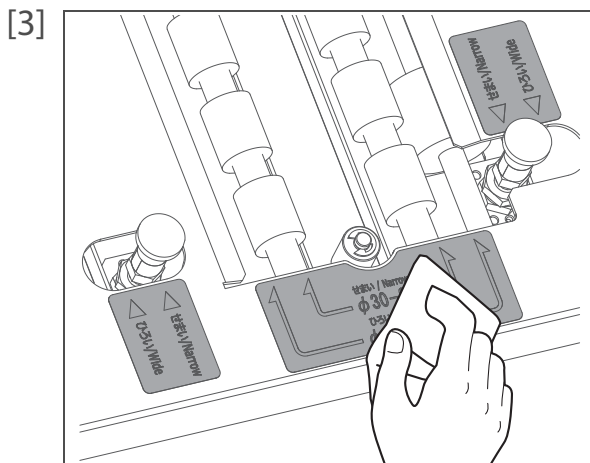

Clean off dirt on the surface of Rotary Unit and instruction labels.

Maintenance on Printer

The printer can be put into sleep mode while the Rotary Unit is installed in the printer.

When you are not using the printer, always leave the power on and put the printer into the sleep mode while not in use. If you do not put the printer into the sleep mode, the ink inside the printer could settle out and/or coagulate, causing poor image quality or printer failure.

Make sure to follow the instructions on the operation panel to perform daily maintenance.

If you set the printer's sleep mode, the printer performs the following operation.

- Automatic Head cleaning by timer set in the "SetTimer" Menu.
- Ink circulation
- "Little Charge"

Important!

To leave the printer in sleep mode for seven days or more, perform followings once a week:

- **Check the ink level and replace the relevant ink cartridge if "Ink Low" is displayed.**
- **Agitate the ink cartridges.**

Steps



[1] Make sure that the printer's operating condition is as follows:

- The front cover and the maintenance cover are closed.
- The remaining ink level is sufficient.
- The waste ink tank has enough space.

Important!

If you are going to use the sleep mode for a prolonged period of time, first empty the waste ink tank, as follows.

[2] Prepare items required for daily maintenance.

-  VJ-626UF Operation Manual "Preparing for Daily Maintenance"
-  Daily Maintenance Sheet for VJ-626UF

[3]

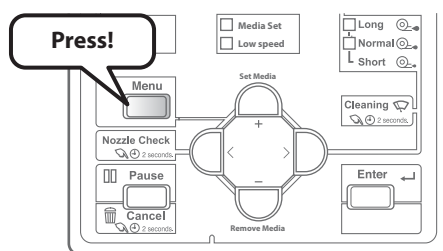

Press the [Menu] key.

Menu1: Setup >

- The message on the left will appear.

[4]

Menu 6: Sleep Mode >

- Press the [-] key several times, to bring up the display on the left.
- Press the [>] key.

[5]

SleepMode 1:	Start
---------------------	--------------

Press the [Enter] key.

[6]

Start Sleep Mode?

Press the [Enter] key.

[7]

Daily Maint. :	Start
-----------------------	--------------

Press the [Enter] key.

Wait for a while

The table moves to the front side of the printer.

[8]

Remove Media	-> Enter
---------------------	--------------------

Remove the media on the Rotary Unit, and then press the [Enter] key.

LoosenThumbScrew	-> E
-------------------------	----------------

The message on the left will appear.

- Open the front cover.

 **Note**

Depending on the media being used, you will not need to loosen the thumbscrew. In such cases, the message "LoosenThumbScrew ->E" will not appear. Go to step 12.

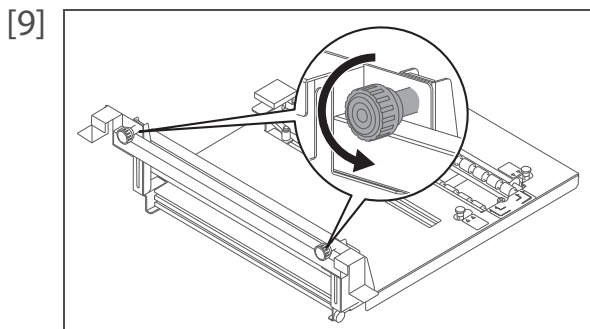

Loosen the thumbscrews (x2) to unlock the attachment.

- After ensuring that both thumbscrews are loosened, close the front cover and press the [Enter] key.

 **Note**

- Rotate the thumbscrews more than half a turn.
- For simplicity, the printer body is excluded in this illustration.

[10]

LoosenThumbScrew?	N
--------------------------	----------

Press the [-] key.

[11]

LoosenThumbScrew?	Y
--------------------------	----------

Press the [Enter] key.

Wait for a while

The table, carriage and cleaning wiper move to gain access to daily maintenance.

[12]

Daily Maint. :	End
-----------------------	------------

The message on the left will appear.

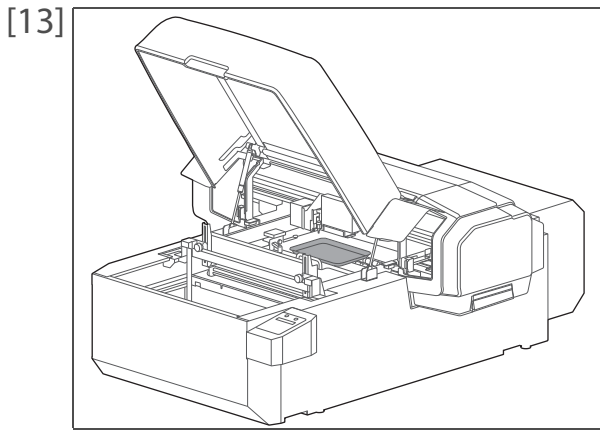

Open the front cover, and then place the tray on the Rotary Unit.

- [14] You can start daily maintenance.
- 👉 VJ-626UF Operation Manual “Performing Daily Maintenance”
 - 👉 Daily Maintenance Sheet for VJ-626UF
 - After the daily maintenance is complete, press the [Enter] key.

TightenThumbScrew -> E

The message on the left will appear.

- Open the front cover.

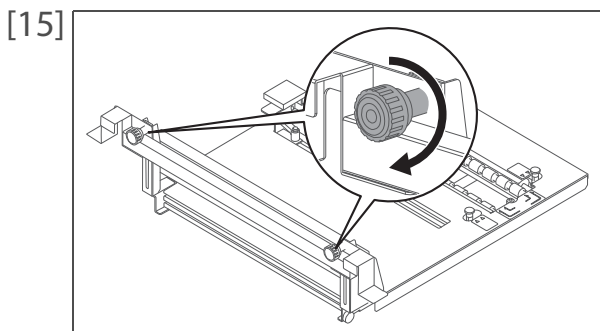

Tighten the thumbscrews until the attachment is locked.

- After ensuring that the thumbscrews on both left and right are tightened, close the front cover and press the [Enter] key.

 **Note**

- Rotate the thumbscrews more than half a turn.
- For simplicity, the printer body is excluded in this illustration.

[16] **TightenThumbScrew?** N

Press the [-] key.

[17] **TightenThumbScrew?** Y

Press the [Enter] key.

Cleaning ** %

The printer automatically performs the “Short” cleaning.

Restart -> **Enter**

The sleep mode will start.

- To exit the sleep mode, press the [Enter] key.

 **Note**

- The power button flashes in blue while the printer is in the sleep mode.
- To set the timer for automatic head cleaning during sleep mode, see “SleepMode 2: SetTmer” of the VJ-626UF Operation manual.

Messages and Error Messages



Note

If you are using Rotary Unit on the printer other than VJ-626UF, see the relevant operation manual for panel operation.

["About the operation manual" P.3](#)



Status messages

When the printer is operating correctly, each operation status is displayed on the operation panel as below. For other messages, see the VJ-626UF Operation Manual.

Display	Description
Install RotaryUnit ->E	Install the Rotary Unit and then press the [Enter] key.
Install Unit? Yes	Check that the Rotary Unit is installed and then press the [-] key.
Install Unit? No	Check that the Rotary Unit is installed and then press the [Enter] key.
Loosen Thumb Screw ->E	The printer will move the table up or down. Loosen the thumbscrews on the Unit, and then press the [Enter] key on the operation panel.
Loosen Thumb Screw? N	Check that the thumbscrews are loosened and then press the [-] key.
Loosen Thumb Screw? Y	Check that the thumbscrews are loosened and then press the [Enter] key.
Dia *.*.* mm / Narrow?	You are changing the user type. Check that the diameter and roller pitch settings displayed match with the size of object you want to use. "Change the User Type" P.31
Adj. PitchToWide ->E	Adjust the roller pitch to "Wide" setting and then press the [Enter] key.
Adj. PitchToNarrow ->E	Adjust the roller pitch to "Narrow" setting and then press the [Enter] key.
AdjustRollerPitch? N	Check that the roller pitch is adjusted and then press the [-] key.
AdjustRollerPitch? Y	Check that the roller pitch is adjusted and then press the [Enter] key.
Tighten Thumb Screw ->E	The printer will move the table back and forth. Tighten the thumbscrews on the Unit, and then press the [Enter] key on the operation panel.
Tighten Thumb Screw? N	Check that the thumbscrews are tightened and then press the [-] key.
Tighten Thumb Screw? Y	Check that the thumbscrews are tightened and then press the [Enter] key.
Install DummyTable ->E	Install the dummy table and then press the [Enter] key.
Install Table? No	Check that the dummy table is installed and then press the [-] key.
Install Table? Yes	Check that the dummy table is installed and then press the [Enter] key.
Load Media for NzChk	Place the new media on the dummy table, and then press the [SetMedia] key. "To run the third nozzle check print" P.20
Remove DummyTable ->E	Remove the dummy table and then press the [Enter] key.
Remove Table? No	Check that the dummy table is removed and then press the [-] key.
Remove Table? Yes	Check that the dummy table is removed and then press the [Enter] key.
Remove RotaryUnit ->E	Remove the Rotary Unit and then press the [Enter] key.
Remove Unit? No	Check that the Rotary Unit is removed and then press the [-] key.
Remove Unit? Yes	Check that the Rotary Unit is removed and then press the [Enter] key.

Error message display and remedies

Error messages are displayed when certain failures occur during printer operation.
For other messages, see the VJ-626UF Operation Manual.

Display	Description
Check Rotary Unit	<ul style="list-style-type: none">• When you are installing the Rotary Unit in the printer: The Unit has not been installed correctly. Follow the instruction below to install the Unit again.  "Attaching the Rotary Unit" P.7• When you are removing the Rotary Unit from the printer: The Unit has not been correctly removed as instructed. Follow the instruction below to remove the Unit again.  "Detaching the Rotary Unit" P.36
Cannot Operate	<p>This menu is not available when the Rotary Unit is installed in the printer. Remove the Unit and try again.</p>  "Detaching the Rotary Unit" P.36

Troubleshooting



Note

If you are using Rotary Unit on the printer other than VJ-626UF, see the relevant operation manual for panel operation.

["About the operation manual" P.3](#)

Rotary Unit Installation Issues

Cannot install the unit.

Did you select "Rotary Unit" from the Option menu on the operation panel before installing the unit?

- Go to "Menu 5: Option>" to select "Option1: Rotary Unit", then follow the instructions to install the unit.

Did you fit the registration pins on the Rotary Unit into the guide holes on the printer?

- Fit the registration pins on the both sides of Rotary Unit into the guide holes on the printer, then install the Rotary Unit.

Are there any deformation, damage or missing parts on the Rotary Unit?

- If any, you cannot use the Rotary Unit. Contact your local MUTOH dealer.

Cannot move on to the next step.

Did you attach the unit detection plate to the obstacle detection sensor?

- If not, an error message ("Check Rotary Unit") will appear on the operation panel and you will not be able to move on to the next step.

["Put Printer into Rotary Mode" P.7](#), ["Install Rotary Unit" P.9](#)

Media Loading Issues

Object doesn't stay stable on the rollers.

Do you use a cylindrical object?

- Check that the object sits flat on the rollers (not conical, drum, or concave shape).

Is there any bump on the surface of object?

- If the object has a small bump on its surface, place it on the Rotary Unit that the bump does not contact with the rubber of rollers.



Important!

To avoid damage to the print head, place the object that the bump does not contact with the head.

Is your object extremely light, long, or short?

- Avoid using extremely light, long, or short object.

["Requirements for usable media" P.5](#)

Media retainer doesn't hold the item on the rollers properly.

Do you use a cylindrical object with enough length and weight that the media retainer can hold it properly?

- Depending on the shape of object, the media retainer cannot hold the object properly.
- If the length of object is less than 80 mm, the media retainer cannot hold it.
- If you use a light object, the media retainer sometimes hold it too tightly and moves the object upward.

Guide bar touches the object.

Did you enter the correct diameter of object?

- It is recommended to measure the diameter in several places on the object and enter the average value.

Did you enter the diameter of object that is smaller than the actual diameter?

- Add the amount of contact with the object to the diameter you entered, and enter the value in the Diameter menu.

The gap between the object and guide bar is too large.

Did you enter the correct diameter of object?

- It is recommended to measure the diameter in several places on the object and enter the average value.

Did you enter the diameter that is larger than the actual diameter?

- Subtract the distance between the guide bar and surface of object from the diameter you entered, and enter the value in the Diameter menu.

Entered the diameter of object correctly, but the distance between the head and object is not appropriate.

Are two rollers on the Rotary Unit set to the same roller pitch setting ("Narrow" or "Wide")?

- Set all pitch adjustment knobs (x4) to the same setting ("Narrow" or "Wide").

Did you match the roller pitch on the Rotary Unit to the Roller Pitch setting on the operation panel?

- If it does not match, the printer cannot adjust the head height correctly.

Did you place the guide bar on the correct position to check the head height?

- Place the right side of the guide bar on the guide plate on the printer to check the head height.

 "Loading the media" P.24

Noise occurs while printing.

Does the object stay stable on the rollers?

- Place the object to sit flat on the rollers.

Is there any obstacle on the surface of cylindrical object?

- Clean the surface of object, then place it on the Rotary Unit.
If any obstacle is present on the object, you may not achieve the predictable print result.

Is there any cured ink, dust, or obstacle on the rubber roller?

- Clean the surface of rubber roller, then place a cylindrical object.
If any obstacle is present on the rubber, you may not achieve the predictable print result.

- If you cannot remove cured ink on the roller, please do NOT use the Rotary Unit.
Contact your local MUTOH dealer.

Is there any damage on the moving parts (rollers, belt, bearing, etc.)?

- If you find any damage, stop using it immediately and contact your local MUTOH dealer.

Cannot change the roller pitch.

Is there any damage on the pitch adjustment knobs?

- If any, contact your local MUTOH dealer.

Did you pull up the pitch adjustment knob and rotate it anticlockwise by 90 degrees to unlock it?

- Make sure to unlock the knob, then change the roller pitch.

Did you slide the right and left knobs at a time?

- Do NOT slide one knob only or two knobs separately. The roller cannot move correctly.

- If it is difficult to change the roller pitch while Rotary Unit is installed in the printer, remove the Rotary Unit from the printer, then change the roller pitch.

Noise or vibration occurs while the table moves up or down.

 **Important!**

If the printer makes unusual noise, remove the Rotary Unit from the printer, then reboot the printer (in such cases, it will not prompt an error message.)

Did you follow the instructions on the operation panel to loosen or tighten thumbscrews?

- Make sure to follow the instructions to loose or tighten the thumbscrews.

 **Important!**

If the printer moves the table up without loosening the thumbscrews, it can cause the damage to the Rotary Unit.

When you loosen the thumbscrews, did you rotate them more than half a turn?

- Make sure to rotate the thumbscrews more than half a turn to unlock, and check that the attachment can slide up and down smoothly.

Did you measure the wight of object?

- A cylindrical object up to 1.0 kg can be loaded.

 ["Loading the media" P.24](#), ["Maintenance on Rotary Unit" P.41](#), ["How To Correct Error After Power Off" P.39](#)

Printer doesn't expectedly print (ink mottle, ink bleed or faint print appears)

<p>Do you use a cylindrical object?</p> <p>- Check that the object sits flat on the rollers (not conical, drum, or concave shape).</p>
<p>Is there any label on the cylindrical object?</p> <p>- If yes, remove the label, then start printing.</p>
<p>Is your object extremely light, long, or short?</p> <p>- Avoid using extremely light, long, or short object.</p>
<p>Do you use the media retainer?</p> <p>- Media retainer is recommended to use only when a cylindrical object does not stay on the rollers while printing. Check that the printer can print on the object properly without using the media retainer.</p>
<p>Are Nozzles in good condition?</p> <p>- Perform Nozzle check. Then if nozzle missing is found, conduct head cleaning. - Perform Daily Maintenance. - The problem still persists, perform "LittleCharge".</p>
<p>Is Ink cartridge within the validity period?</p> <p>- Use a non-expired ink cartridge.</p>
<p>Did you agitate ink in the cartridge?</p> <p>- When "Shake XX Cartridge" message appears on the operation panel, agitate ink in the cartridge.</p>
<p>Do you perform daily maintenance properly?</p> <p>- Follow the instructions on the VJ-626UF Operation Manual to perform maintenance.</p>

 ["Requirements for usable media" P.5](#), ["Loading the media" P.24](#), ["Nozzle check and cleaning" P.14](#), ["Maintenance on Printer" P.42](#)

Printed color is not accurate.

Are Nozzles in good condition?

- Perform Nozzle check. Then if nozzle missing is found, conduct head cleaning.
- Perform Daily Maintenance.
- The problem still persists, perform "LittleCharge".

Did you agitate ink in the cartridge?

- When "Shake XX Cartridge" message appears on the operation panel, agitate ink in the cartridge.

Nozzle missing remains after head cleaning.

Is there any ink stains or deposits on the cleaning wiper or circumference of the print head?

- Perform head cleaning or "Little Charge" again and check the nozzle check print.
- Perform Daily Maintenance and check the nozzle check print.
- The problem still persists, contact your local Mutoh dealer.

 **Important!**

Do NOT use light reflective object like a mirror or light transparent object that can cause irregular reflection of UV light. This will cure the ink on the print head.

Document was printed with wrong size (enlarged, reduced, wider, longer...).

Did you select "Rotary Unit" from the Choose Media dropdown list in Layout and Print Tool 2?

- Check that Rotary Unit is selected from the Choose Media dropdown list.

Did you attempt to print an image directly from RIP software or printer driver?



- A print file must be 720 x 1080 dpi with L dot setting.
- Use Layout and Print Tool 2 to create a print file.

 ["Nozzle check and cleaning" P.14](#), ["Maintenance on Printer" P.42](#), ["Basic printing instructions" P.32](#)



Safety Instructions

About the safety notices

Signification of WARNING and CAUTION

 WARNING	Used for dangerous situations where death or serious injury may be caused.
 CAUTION	Used for dangerous situations that may cause slight or medium injury, or when all or parts of products are damaged.

Meaning of symbols

Warning symbol	Meaning
	Indicates "prohibited" operations.
	Indicates "required" operations.

When Storing Rotary Unit

WARNING



Do NOT place this Unit

- on the area where is not stable or not level
- on the floor with busy area
- on the tall shelf

On such places, the Unit could fall off or people can trip over.

CAUTION



When storing this Unit,

- keep out direct sunlight
- avoid high temperature, high humidity and high dust
- avoid vibration from other devices.

If not, it causes damage to the Unit, leading to malfunction.

Concerning handling the Unit

CAUTION



Do NOT step on or place items on this Unit.

If not, it causes damage to the Unit, leading to malfunction.



- When moving this Unit, always hold the handle with one hand, and put the other hand lightly on the attachment or side of the product.

Do NOT hold rollers or media retainer. It can cause damage to the Unit.

- When holding the side of the product, make sure to hold the black cover and silver frame on each side of the unit.

If holding the black cover only, you may have a chance to drop the product or the cover can be deformed, leading to poor print quality.



Do not use volatile solvents such as thinner, benzene, or alcohol.

These solvents may cause damage to the paint.



- When loading a new media, make sure to place it on an appropriate position and input correct media information.

If wrong information is entered, the printer can print on an unintended position on the Rotary Unit. Once UV ink cures on the Unit, you can hardly remove it.

When Handling UV Ink

Extra care must be taken when handling UV ink. Before use, read instructions on the VJ-626UF Operation Manual and safety data sheet (SDS) of the UV ink.

Instruction labels

Operation instruction labels are applied on the printer at places where caution in operation is required. The contents of these labels are as shown below.

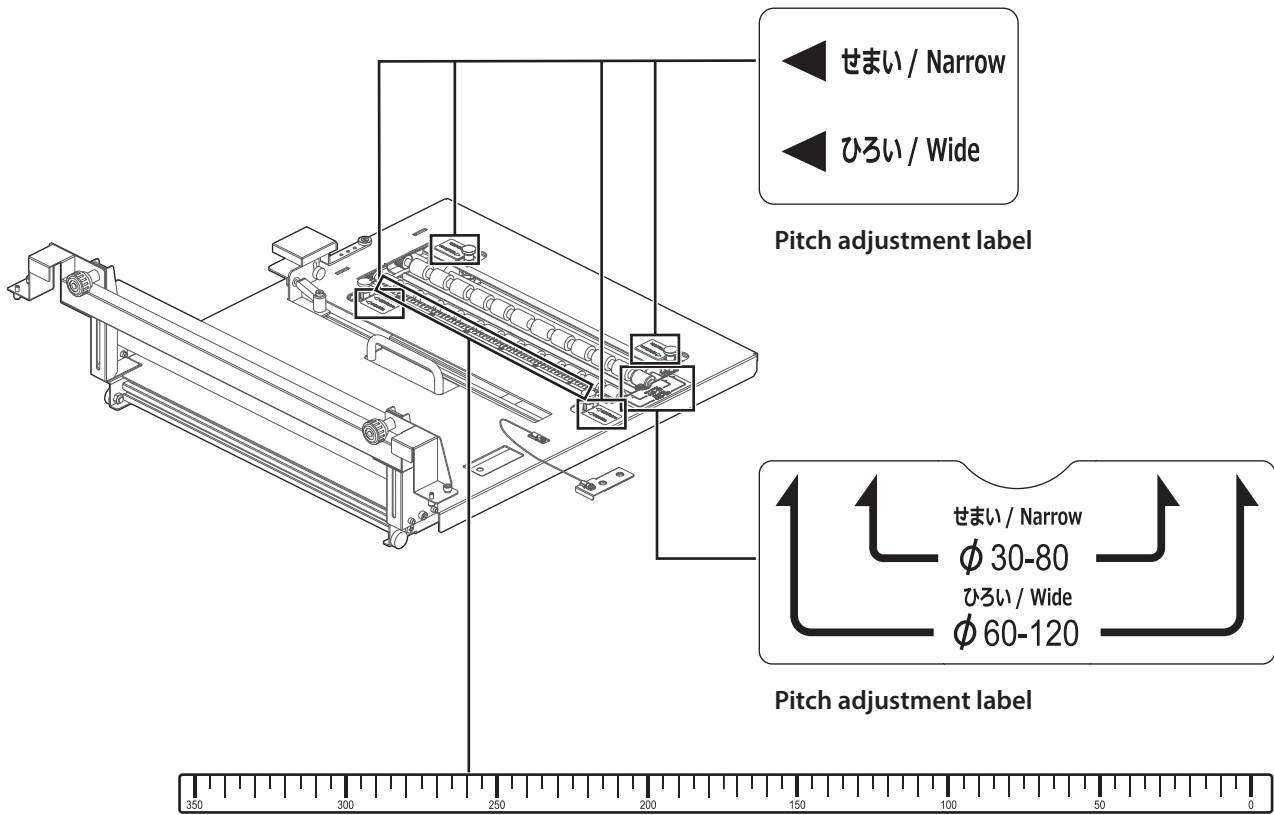

Scale label

350 mm scale in 5 mm divisions from the media origin (0).

Revision history

Date	Version	Manual code	Supported Firmware
2018.2	00	ROTAUTE-A-00	V.1.03
2018.7	01	ROTAUTE-A-01	V.1.04
2020.2	02	ROTAUTE-A-02	V.1.04 or later

MUTOH